

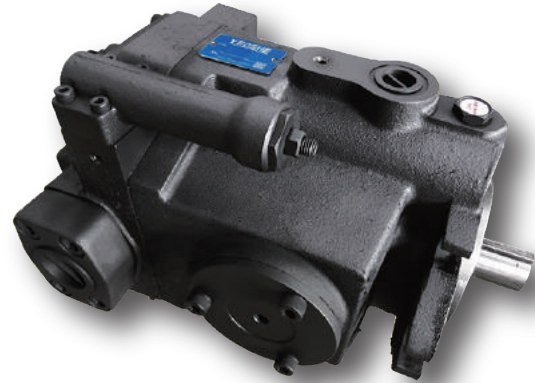

**YEOSHE**

# Hydraulic Piston Pump V Series



[www.yeoshehydraulic.com](http://www.yeoshehydraulic.com)

**Efficient Performance**  
**Innovative Technology**  
**Reliable Quality and**  
**Service**

**YEOSHE HYDRAULICS CO.,LTD.**



# V Axial piston pump

## V Series axial piston pump

A

1

V Axial piston pump



- 1.V Series pump,new design for changeable angle of swash plate,wide applications.
- 2.Special design,low noise level during full pressure time.
- 3.Modular control,easy to design system,advantages are:power saving,small size,low cost.
- 4.Low power consuming,low oil temperature rising,suitable application for assembling small power units.

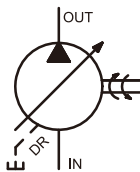

nominal pressure: 175 bar  
 max. pressure: 280 bar  
 single operation period: 250bar /6ms  
 315bar/2.5ms

### Specifications

Size	Model	Displacement at ( 7 bar ) 100 PSI						Pressure Adj. kgf/cm <sup>2</sup>	Speed		Weight KG (LB)
		cm <sup>3</sup> /rev	in <sup>3</sup> /rev	1500 RPM LPM U.S. GPM	1800 RPM LPM U.S. GPM	Max. RPM	Min. RPM				
1	V 8	8.0	0.48	12.0 3.17	14.4 3.8	1: 8~70 2: 15~140 3: 20~210 4: 20~250	1800	500	13 (28.6)		
	V10	10.0	0.61	15.0 3.90	18.0 4.76				13 (28.6)		
	V12	12.0	0.73	18.0 4.76	21.6 5.73				13 (28.6)		
	V15	15.0	0.90	22.5 5.78	27.0 7.05				13 (28.6)		
	V18	17.8	1.09	26.7 7.05	32.0 8.45				13 (28.6)		
2	V23	23.0	1.40	35.4 9.11	41.4 10.94	1: 8~70 2: 15~140 3: 20~210	1800	500	22 (48.4)		
	V25	25.0	1.52	37.5 9.66	45.0 11.60				22 (48.4)		
3	V38	37.8	2.31	56.7 14.98	68.0 17.96	1: 8~70 2: 15~140 3: 20~210	1800	500	26 (57.2)		
	V42	42.0	2.56	63.0 16.23	76.0 19.58				26 (57.2)		
4	V50	51.5	3.14	77.2 20.37	92.7 24.48	1: 8~70 2: 15~140 3: 20~210	1800	500	56 (123.2)		
	V70	69.7	4.25	104.5 27.6	125.4 33.10				56 (123.2)		

- 1.Install outlet on top,the pipe pressure needs less than 2bar.
- 2.Using at max.pressure,please undre 6 sec for per-cycle time.
- 3.Hydraulic oil clean,please following YEOSHE instruction maunal.
- 4.YEOSHE supply combinable pumps with different series,standard with Metric / SAE size.



# Type code for standard program

V	15	A	3	R			-								
1	2	3	4	5	6	7		8	9	10	11	12	13	14	
Series	Size and displacement	Control device	Pressure adjusting	Rotation	Direction of pipe connections	Shaft type		Voltage	Threads type	Thru drive & 2nd pump	Special spec.	Mounting	Seals	Design No.	

## Series

1	Axial piston pump variable displacement high pressure version	nominal pressure: 175 bar max. pressure: 280 bar single operation period: 250bar / 6ms, 315bar/2.5ms	V
---	---	---	---

## Size and displacement

2	Code	8	10	12	15	18	23	25	38	42	50	70	
	Size	1			2			3		4			
	Displacement	cm <sup>3</sup> / rev	8	10	12	15	18	23.0	25.0	37.8	42.0	51.5	69.7
		In <sup>3</sup> / rev	0.48	0.61	0.73	0.90	1.1	1.40	1.52	2.31	2.56	3.14	4.25

## Control device

3	Standard pressure control	A	※
	Remote pressure control	G	
	Load-sensing control	HL□	
	Pressure		
	A	Low : 7KG	
	B	Mid : 14KG	
	C	High : 21KG	
	Muti-stage flow & Singe-stage pressure control (with cylinder)	B	
	2-stage pressure & Flow control	C	
	2-stage pressure & Flow control + Remote	CG	
	2-stage pressure & Flow control + Low tension unloading	CR	
	Low tension unloading + Pressure control	D	
	Low tension unloading + Pressure control + Remote	DG	
	Electric 2-stage pressure control	E	
	Electric 2-stage pressure control + Remote	EG	
	Electric 2-stage pressure control & Flow control	F	
	Electric 2-stage pressure control & Flow control + Remote	FG	
	Remote pressure compensator with NG6 interface	GM	
	Remote pressure compensator + Proportional pressure valve	GJ	
	Remote pressure compensator + Electrical unloading	GR	
	Remote pressure compensator + 2-stage pressure control	GB	
	Remote pressure compensator + Electrical unloading + 2-stage pressure control	GC	
	Load-sensing compensator + Proportional flow valve + Relief valve	HQ□	
	Pressure		
	A	Low : 7KG	
	B	Mid : 14KG	
	C	High : 21KG	
	Load-sensing compensator + Proportional pressure valve + Proportional flow valve	HK□	
	Pressure		
	A	Low : 7KG	
	B	Mid : 14KG	
	C	High : 21KG	

## Type code for standard program

V	15	A	3	R			-								
1	2	3	4	5	6	7		8	9	10	11	12	13	14	
Series	Size and displacement	Control device	Pressure adjusting	Rotation	Direction of pipe connections	Shaft type		Voltage	Threads type	Thru drive & 2nd pump	Special spec.	Mounting	Seals	Design No.	

## Pressure adjusting

4	8~70 bar (0.8~6.9 Mpa)	1
	15~140 bar (1.5~13.7 Mpa)	2
	20~210 bar (2.0~20.6 Mpa)	3
	20~250 bar (2.0~24.5 Mpa)	4

## Rotation

5	 Clockwise	R
	 Counter clockwise	L

## Direction of pipe connections

		8	10	12	15	18	23	25	38	42	50	70	
6	None: Side port (Flange)	■	■	■	■	■	■	■	■	■	■	■	☐ ※
	Rear port (Flange)	-	-	-	-	-	■	■	■	■	■	■	B
	Side port + Rear port (Flange)	-	-	-	-	-	■	■	■	■	-	-	B2

## Shaft type

Displacement	Code
None	Key: ☐
7	V15,V18 Splind shaft: ☐ S ☐ 13T 16/32 DP ☐ S1 ☐ 9T 16/32 DP ☐ S2 ☐ 11T 16/32 DP
	V23,V25 Splind shaft: ☐ S ☐ 13T 16/32 DP △ ☐ S1 ☐ 15T 16/32 DP △ ☐ S3 ☐ 13T 16/32 DP longer
	V38,V42 Splind shaft: ☐ S ☐ 13T 16/32 DP ☐ S1 ☐ 15T 16/32 DP ☐ S3 ☐ 13T 16/32 DP longer
	V50,V70 Splind shaft: ☐ S ☐ 14T 12/24 DP △ ☐ S1 ☐ 17T 12/24 DP

## Voltage

8	None	☐
	AC100V (50/60HZ)	A
	AC110V (60HZ)	B
	AC220V (50/60HZ)	C
	AC220V (60HZ)	D
	DC 12V	E
	DC 24V	F ※

■ = available - = on request ※ = standard type △ = custom made



# Type code for standard program

A

4

V Axial piston pump

V	15	A	3	R			-								
1	2	3	4	5	6	7		8	9	10	11	12	13	14	
Series	Size and displacement	Control device	Pressure adjusting	Rotation	Direction of pipe connections	Shaft type		Voltage	Threads type	Thru drive & 2nd pump	Special spec.	Mounting	Seals	Design No.	

### Threads

9	PT (RC)	■	■	■	■	■	■	■	■	■	■	■	■	■	10	※
	BSPP (G)	■	■	■	■	■	■	■	■	■	■	■	■	■	40	※
	NPT	△	△	△	△	△	△	△	△	△	△	△	△	△	50	
	UNF (SAE o-ring)	■	■	■	■	■	■	■	■	■	■	■	■	■	60	
	Metric	△	△	△	△	△	△	△	△	△	△	△	△	△	70	

### Thre drive & 2nd pump

10	without thru drive	<input type="checkbox"/>
	Ø 50.8 mm SAE AA	C
	Ø 82.55 mm SAE A	D
	Ø101.6 mm SAE B	E
	Ø 127 mm	F
	Ø 63 mm	I
	Ø 80 mm	J
	Ø 100 mm	K
	Ø 125 mm	L

(Plesae contact YEOSHE,if other size required.)

### Special specification

11	Standard type	X	※
	Low Pressure type	X1	
	Deahead pressure relief type	Z	

### Mounting

12	Only for V15, V18 can select "A", other displacement only select "None:Standard"	None : Standard	<input type="checkbox"/>	※
		SAE A 2 bolt	A	

### Seals

13	NBR	<input type="checkbox"/>	※
	VITON	A	

■ = available - = on request ※ = standard type △ = custom made

# Control type

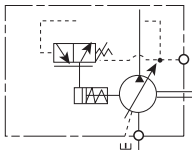
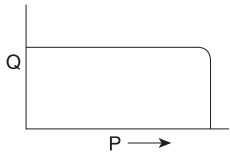
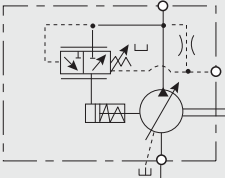
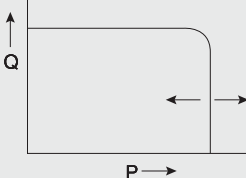
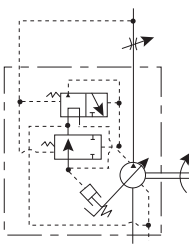
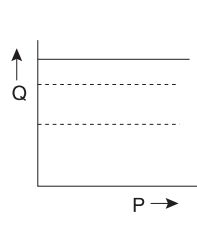
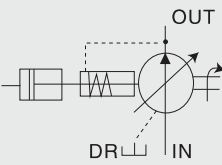
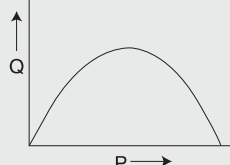
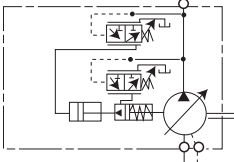
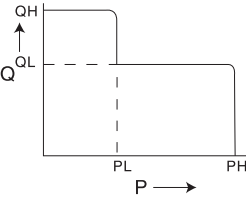
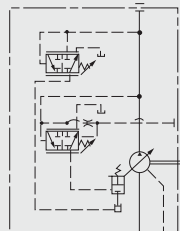
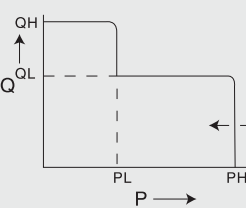
Controls	Symbol	Characteristic	Specifications
A type: Standard pressure control			<ol style="list-style-type: none"> <li>When system pressure increase and reach present pressure the flow decrease automatically and pressure to be constant.</li> <li>Pressure and flow can be adjusted manually.</li> </ol>
G type: Remote pressure control			<ol style="list-style-type: none"> <li>The same function of "A" control type.</li> <li>Pressure can be adjusted remotely by the remote control valve.</li> </ol>
HL type: Load-sensing control			<ol style="list-style-type: none"> <li>HL valve with 2 different pressure, control displacement .</li> <li>The flow can be changed by HL valve, the sensing feedback can reach low oil temperature and energy saving.</li> </ol>
B type: Multi-stage flow & Singe-stage pressure control (with cylinder)			<ol style="list-style-type: none"> <li>Flow can be adjusted from 0 to maximum and pressure can be maintaining at preset pressure.</li> <li>Absorbing impact and vibration which are produced by up down motions . It is suitable for lifting equipment etc.</li> </ol>
C type: 2-stage pressure & Flow control			<ol style="list-style-type: none"> <li>2-stage pressure to adjust PL to QH and : PH to QL.</li> <li>When pressure increase and reach preset pressure "PH", flow is reduced to "QL".</li> <li>Adapt for long dead head and short pressurizing machines, speedy and energy saving.</li> <li>Pressure "PH""PL", and flow "QH""QL" can be adjusted optionally.</li> </ol>
CG type: 2-stage pressure & Flow control + Remote			<ol style="list-style-type: none"> <li>The same function of "C" control type.</li> <li>The pressure and the range can be adjusted by remote control valve.</li> <li>Install YEOSHE solenoid control valve to reach good performance.</li> </ol>



# Control type

A

6

V Axial piston pump

Controls	Symbol	Characteristic	Specifications
<b>CR type:</b> 2-stage pressure & Flow control + Low tension unloading			<ol style="list-style-type: none"> <li>1. Install YEOSHE solenoid valve, control 2-stage pressure.</li> <li>2. It is suitable for constant speed lifting equipments, and setting 2-stage working pressure.</li> <li>3. PL and PH, two options can be PH.</li> </ol> <p>SOL OFF: Low tension unloading                      SOL OFF: 2-stage pressure&amp;flow</p>
<b>D type:</b> Low tension unloading + Pressure control			<ol style="list-style-type: none"> <li>1. Same as type A and with low tension unloading.</li> <li>2. It is adapt for long unloading operation.</li> <li>3. When the system stops, oil temperature and noise maintain low level while being through the unloading.</li> </ol>
<b>DG type:</b> Low tension unloading + Pressure control + Remote			<ol style="list-style-type: none"> <li>1. The same function of "D" control type.</li> <li>2. The pressure and the range can be adjusted by remote control valve.</li> <li>3. Install YEOSHE solenoid control valve to reach good performance.</li> </ol>
<b>E type:</b> Electric 2-stage pressure control			<ol style="list-style-type: none"> <li>1. 2-stage pressure is controlled by solenoid control valve.</li> <li>2. Adapt for constant speed lifting equipments, and setting 2-stage working pressure.</li> <li>3. PL and PH, two options can be PH.</li> </ol>
<b>EG type:</b> Electric 2-stage pressure control + Remote			<ol style="list-style-type: none"> <li>1. The same function of "E" control type.</li> <li>2. The pressure and the range can be adjusted by remote control valve.</li> <li>3. Install YEOSHE solenoid control valve to reach good performance.</li> </ol>
<b>F type:</b> Electric 2-stage pressure control & Flow control			<ol style="list-style-type: none"> <li>1. Electric 2-stage pressure &amp; flow control to adjust PL to QH, PH to QL.</li> <li>2. Pressure "PL", "PH" and flow "QH" can be adjusted optionally.</li> </ol>

Control type

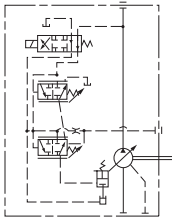
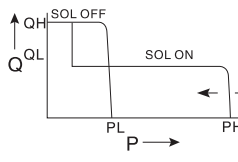
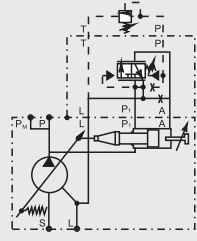
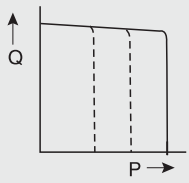
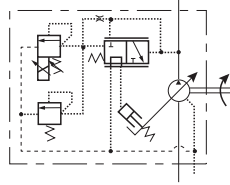
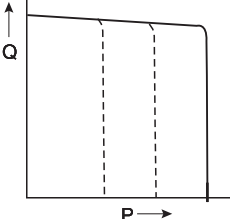
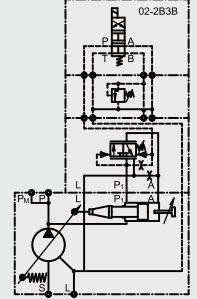
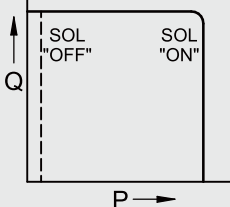
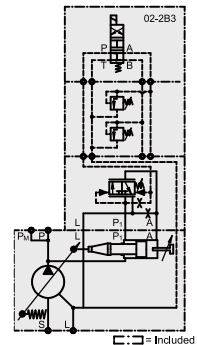
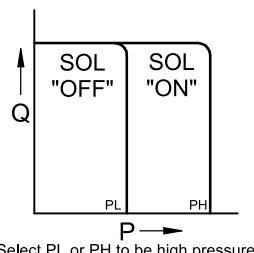
Controls	Symbol	Characteristic	Specifications
<p>FG type: Electric 2-stage pressure control &amp; Flow control + Remote</p>			<ol style="list-style-type: none"> <li>1. Electric 2-stage pressure &amp; flow control to adjust PL to QH, PH to QL.</li> <li>2. Pressure can be adjusted by remote control valve.</li> <li>3. Pressure "PL", "PH" and flow "QH" can be adjusted optionally.</li> </ol>
<p>GM type: Remote pressure compensator with NG6 interface</p>			<ol style="list-style-type: none"> <li>1. GM Remote pressure compensator with NG6 interface.</li> <li>2. Speedy reactions, stable pressure supply.</li> <li>3. Adapt for manual or electric control.</li> </ol>
<p>GJ type: Remote pressure compensator + Proportional pressure valve</p>			<ol style="list-style-type: none"> <li>1. Same as type "GM" and with proportional pressure valve.</li> <li>2. The proportional valve is installed on the NG6 interface to reach proportional electric control to save energy.</li> </ol>
<p>GR type: Remote pressure compensator + Electrical unloading</p>	 <p>E.C. = Included</p>		<ol style="list-style-type: none"> <li>1. By adding a relief valve and solenoid control valve on the compensator makes pump have both function.</li> <li>2. GR control is for long unloading situations. When the system stops, oil temperature and noise maintain low level while being through the unloading.</li> </ol>
<p>GB type: Remote pressure compensator + 2-stage pressure control</p>	 <p>E.C. = Included</p>	 <p>Select PL or PH to be high pressure</p>	<ol style="list-style-type: none"> <li>1. By adding a relief valve and solenoid control valve on the compensator makes pump have both function.</li> <li>2. GB control is for Z-stage working pressure under the constant cylinder speed.</li> </ol>



# Control type

A

8

V Axial piston pump

Controls	Symbol	Characteristic	Specifications
<p>GC type: Remote pressure compensator + Electrical unloading + 2-stage pressure control</p>		<p>Select PL or PH to be high pressure</p>	<ol style="list-style-type: none"> <li>1. Control two different-stage limited pressure by adding solenoid valve and unloading function.</li> <li>2. When the system stops, oil temperature and noise maintain low level by unloading function.</li> <li>3. Adapt for stable cylinder speed, 2-stage pressure, and long unloading situation.</li> </ol>
<p>HQ type: Load-sensing compensator + Proportional flow valve + Relief valve</p>			<ol style="list-style-type: none"> <li>1. HQ control with load-sensing and proportional flow control.</li> <li>2. By electric input signal to adjust pump displacement, and the flow is controlled by electric modular control.</li> </ol>
<p>HK type: Load-sensing compensator + Proportional pressure valve + Proportional flow valve</p>			<ol style="list-style-type: none"> <li>1. HK offers the smallest pressure and flow according to different requirement.</li> <li>2. The displacement is nearly zero when the system stands by, and the motor output is also nearly zero to saving energy.</li> <li>3. When the system reaches setting pressure, the pump displacement will reduce by itself. It only needs to add the system required flow, and the pressure remains the same which control the oil temperature.</li> <li>4. Compared with vane pump, gear pump+PQ valve can save 30-50% energy.</li> </ol>

# Dimension

## V15A, V18A Standard pressure control

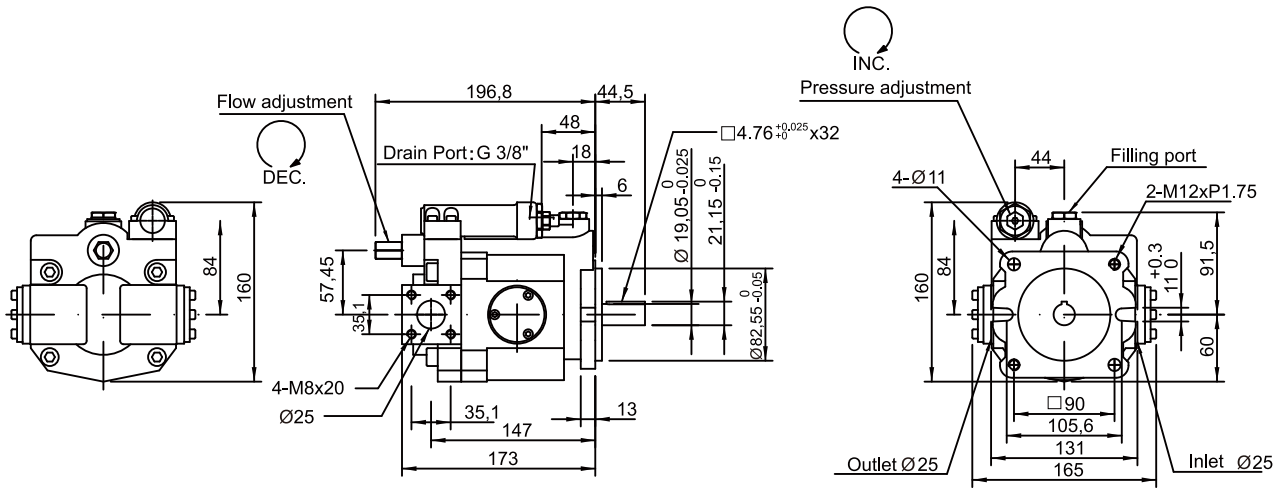

## V15A, V18A Standard pressure control (SAE A 2 bolt) Please following order code no.12

V 15 - - - - - A

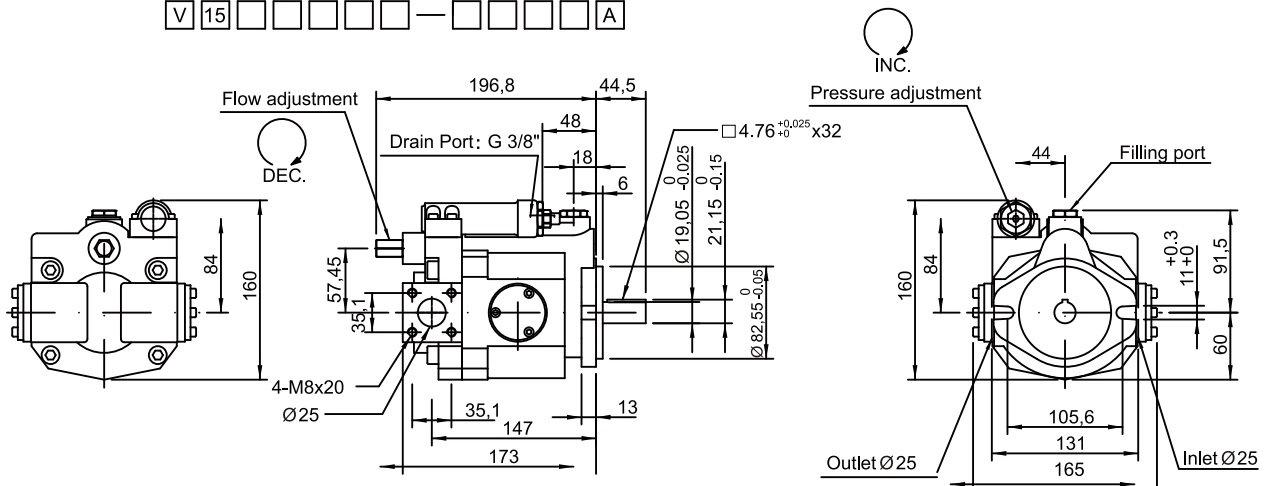

## V15G, V18G Remote pressure control

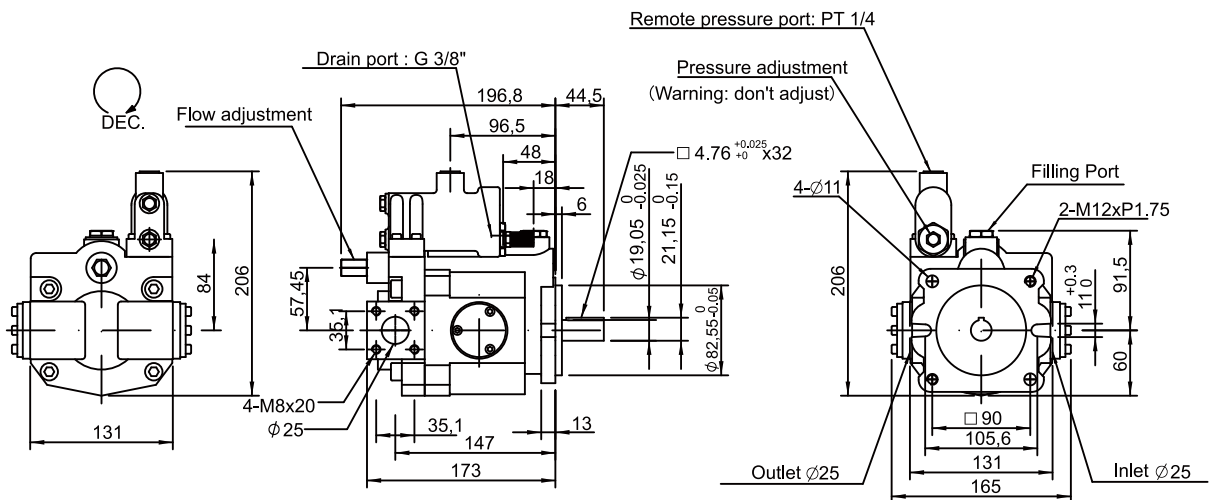

# Dimension

A

10

V Axial piston pump

V15HL, V18HL Load-sensing control

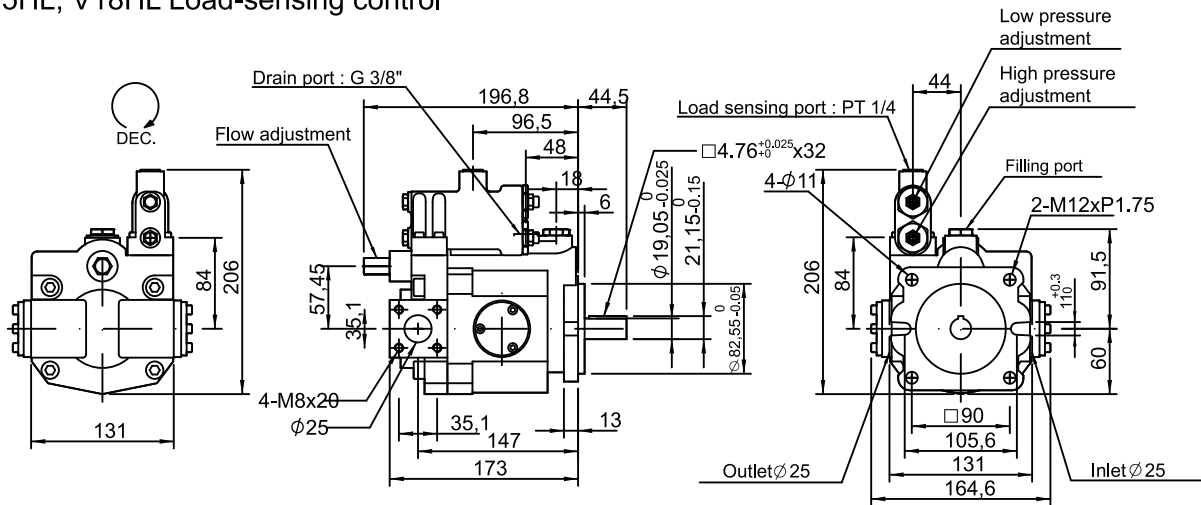

V15B, V18B Multi-stage flow & Single-stage pressure control (with cylinder)

(Remark : Install with A type control)

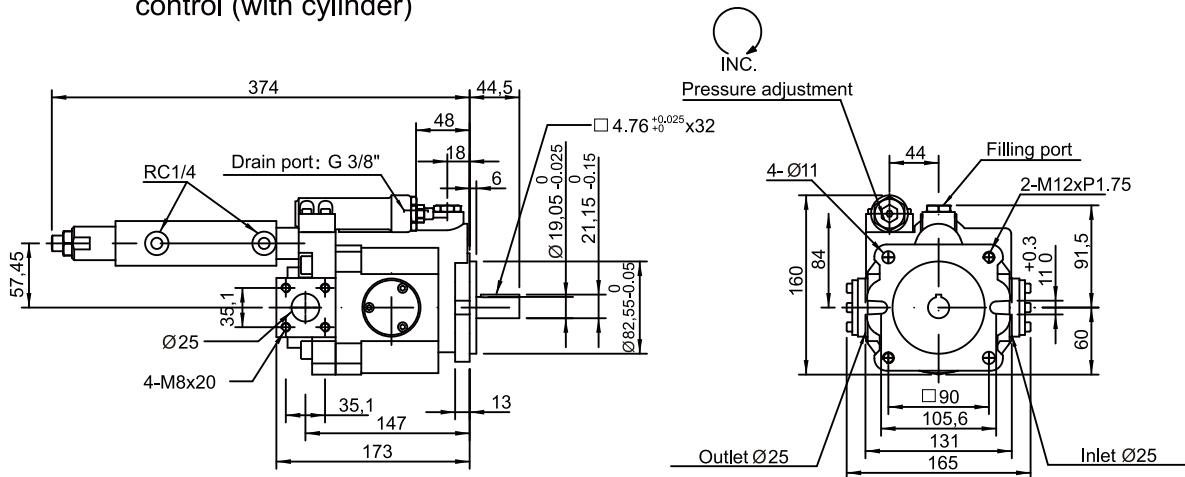

V15C, V18C 2-stage pressure & Flow control

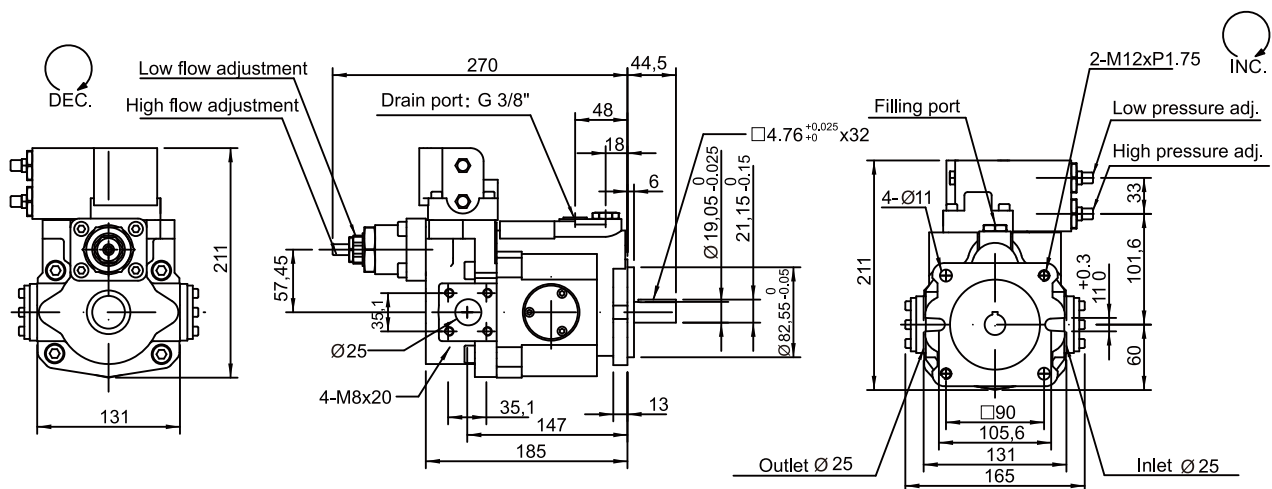

Dimension

V15CG, V18CG 2-stage pressure & Flow control + Remote

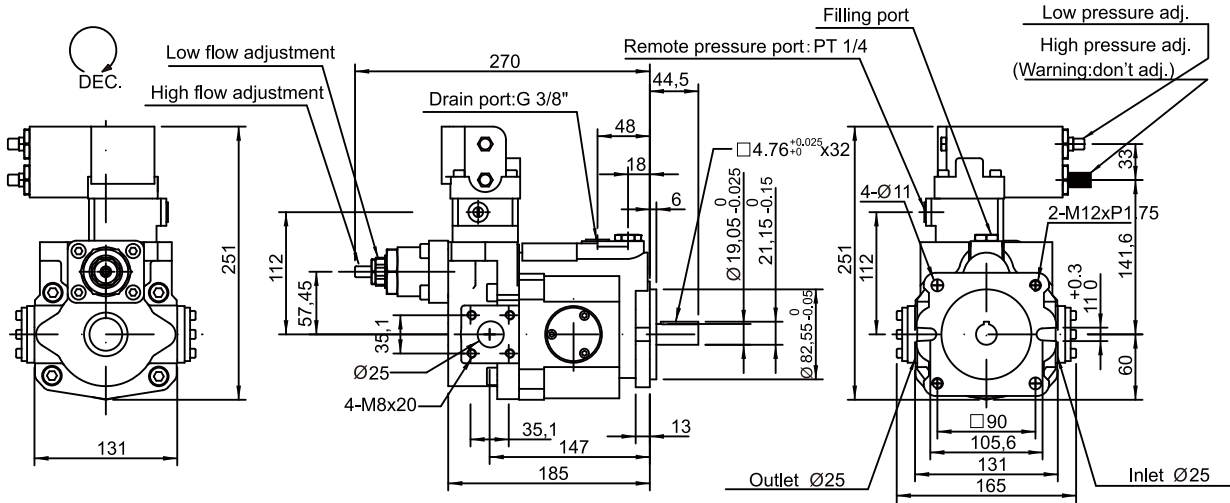

V15CR, V18CR 2-stage pressure & Flow control + Low tension unloading

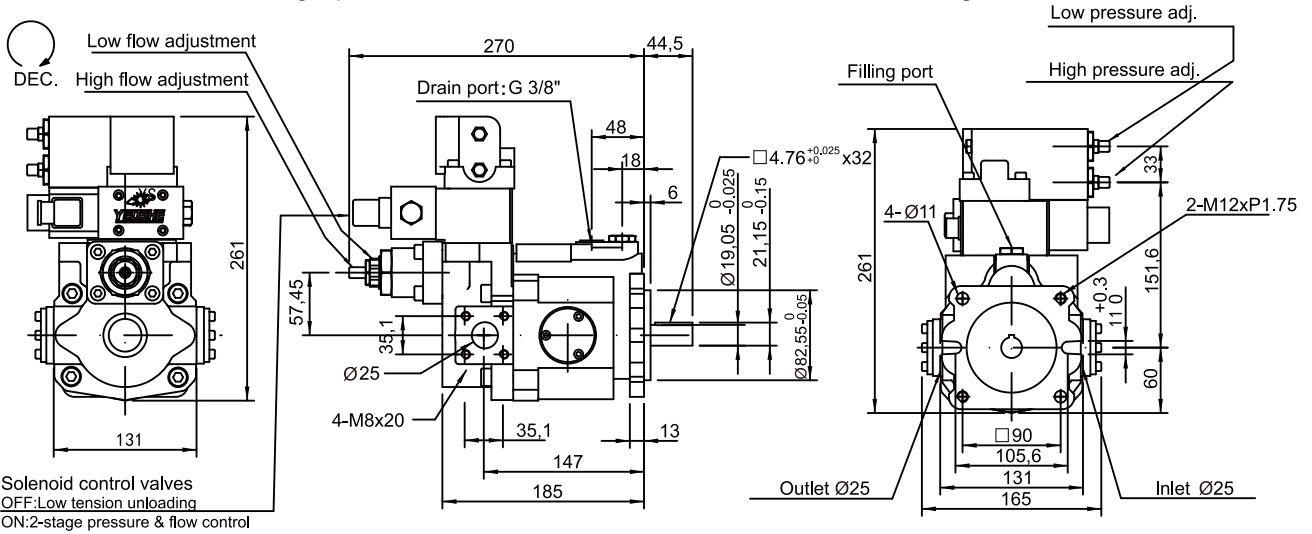

V15D, V18D Low tension unloading + Pressure control

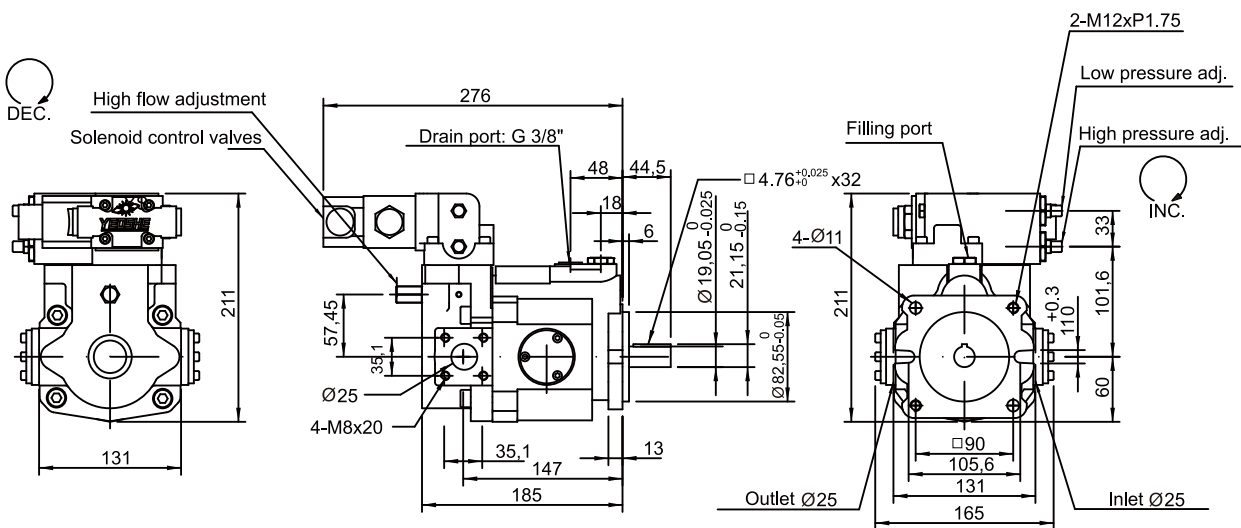



# Dimension

A

12

V Axial piston pump

V15DG, V18DG Low tension unloading + Pressure control + Remote

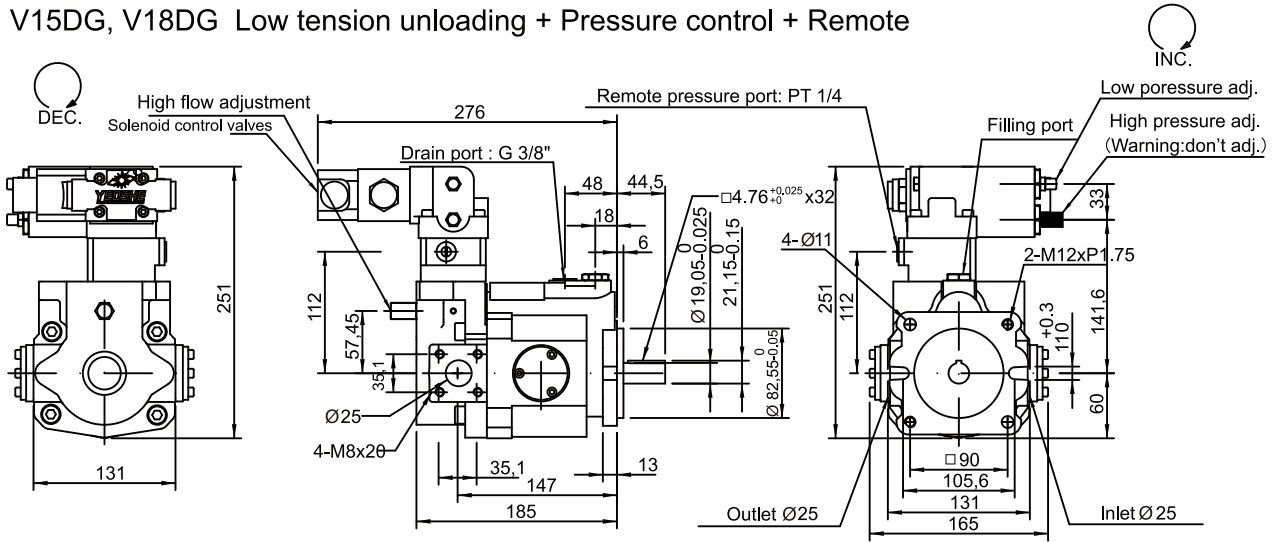

V15E, V18E Electric 2-stage pressure control

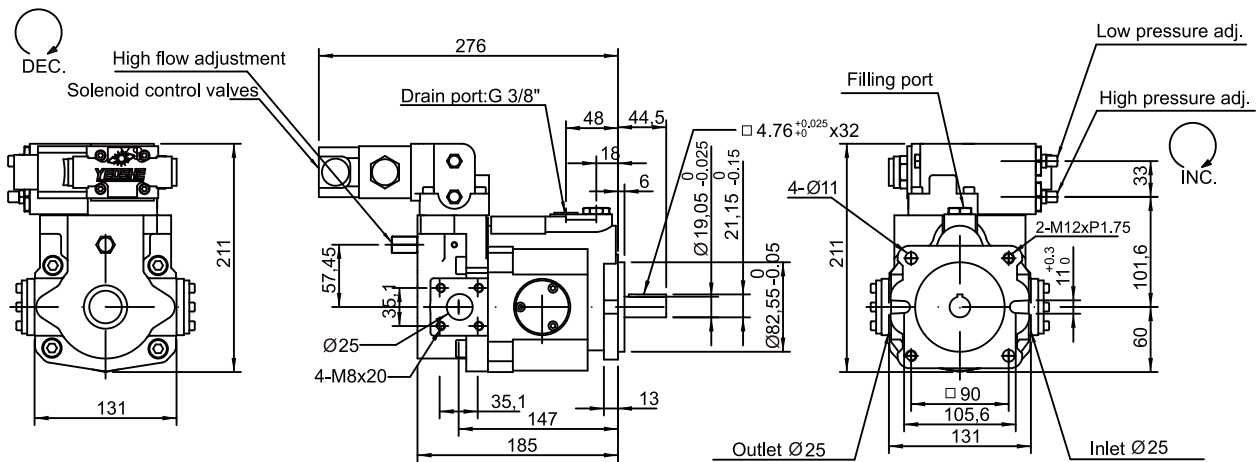

V15EG, V18EG Electric 2-stage pressure control + Remote

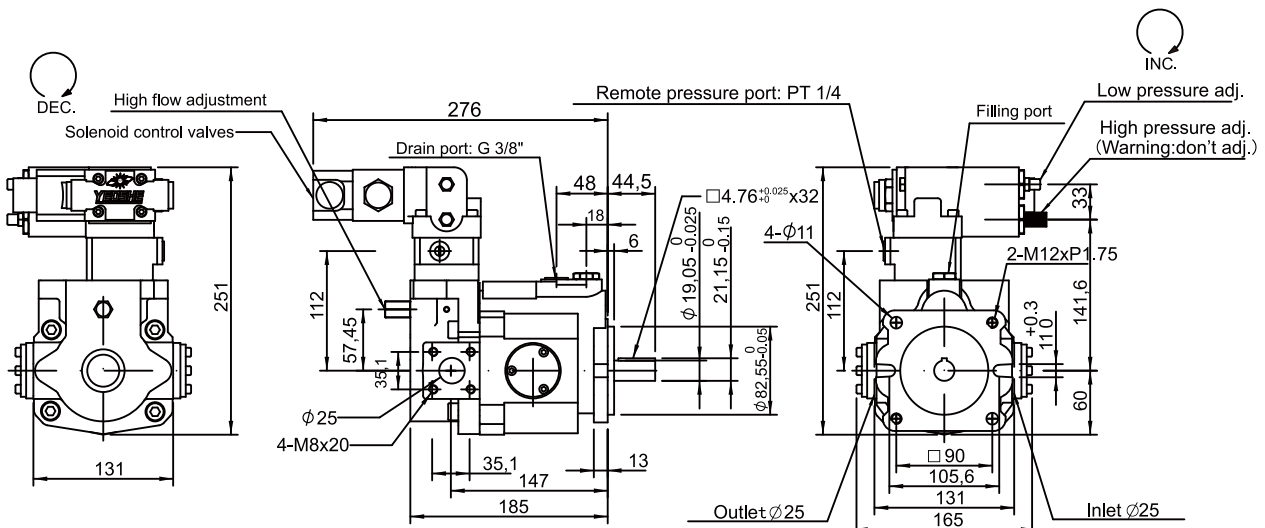

Dimension

V15F, V18F Electric 2-stage pressure control & Flow control

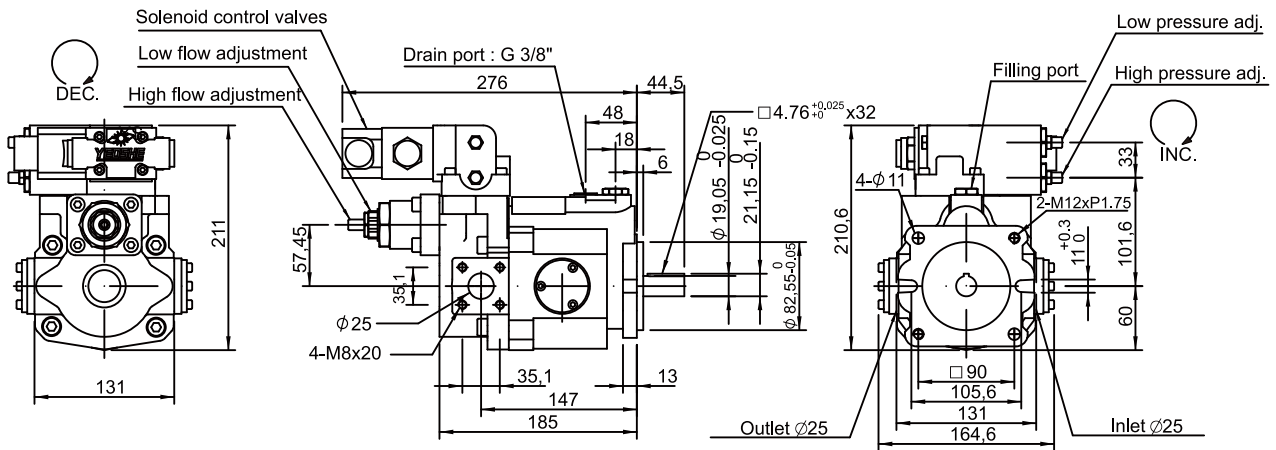

V15FG, V18FG Electric 2-stage pressure control & Flow control + Remote

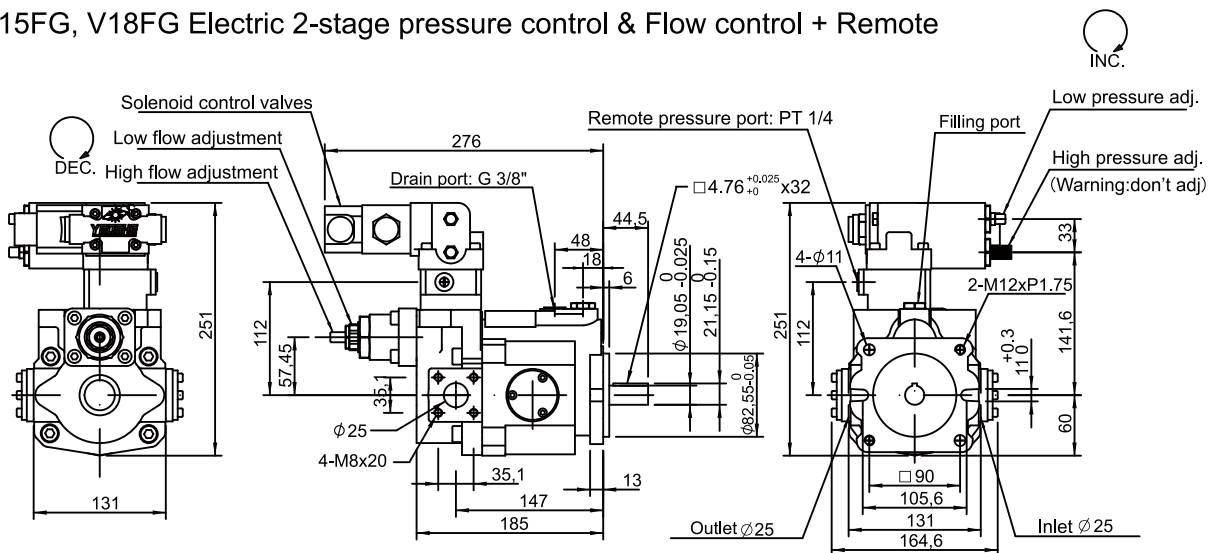

V15GM, V18GM Remote pressure compensator with NG6 interface

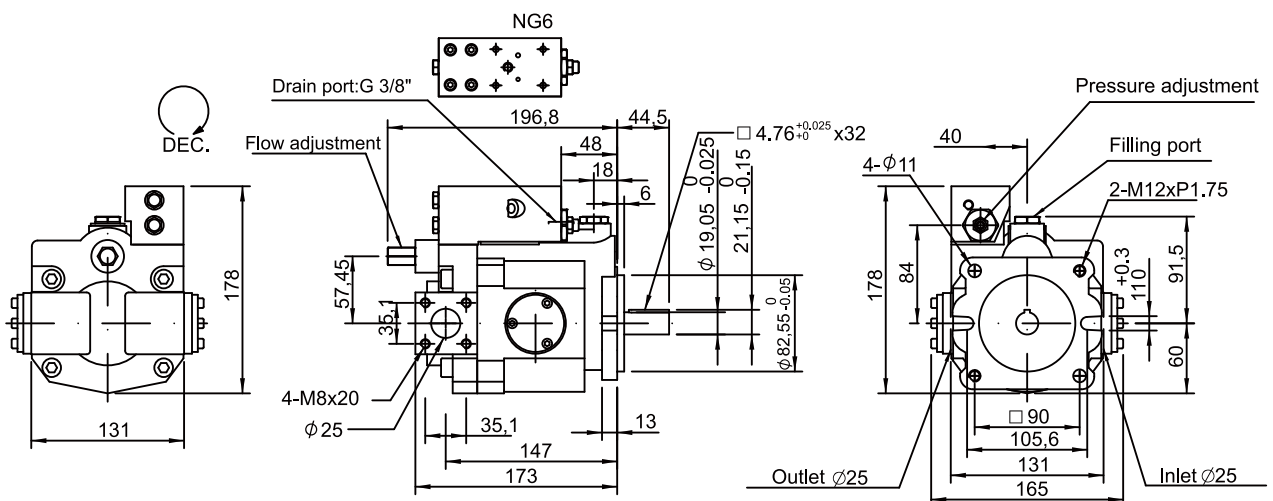

# Dimension

A

14

V Axial piston pump

V15GJ, V18GJ Remote pressure compensator + Proportional pressure valve

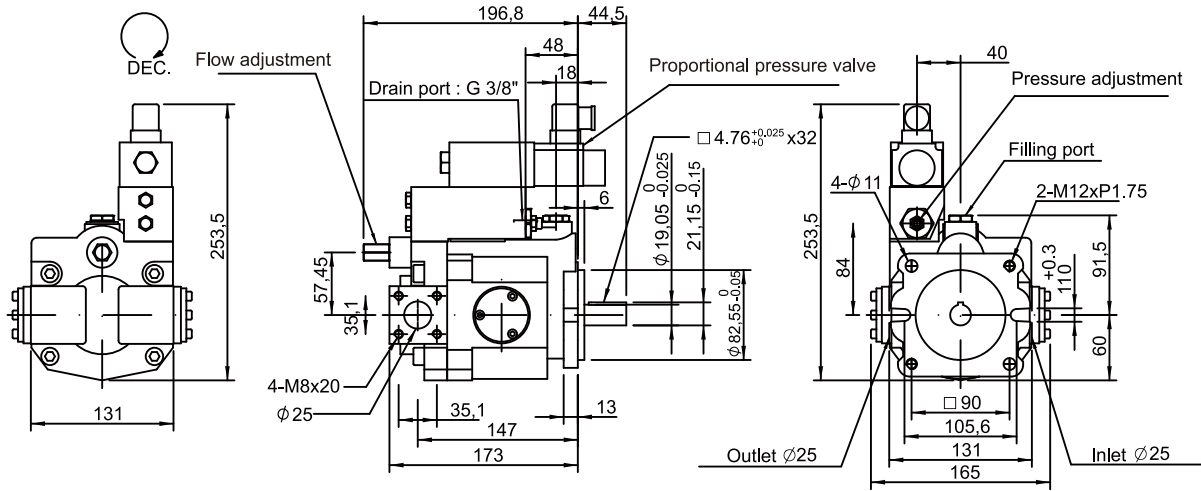

V15GR, V18GR Remote pressure compensator + Electrical unloading

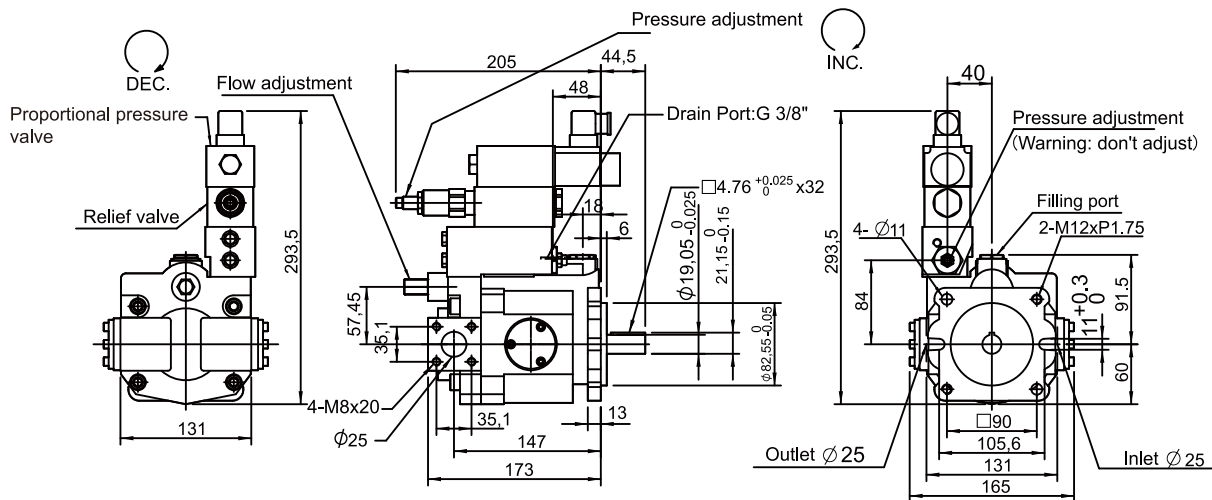

V15GB, V18GB Remote pressure compensator + 2-stage pressure control

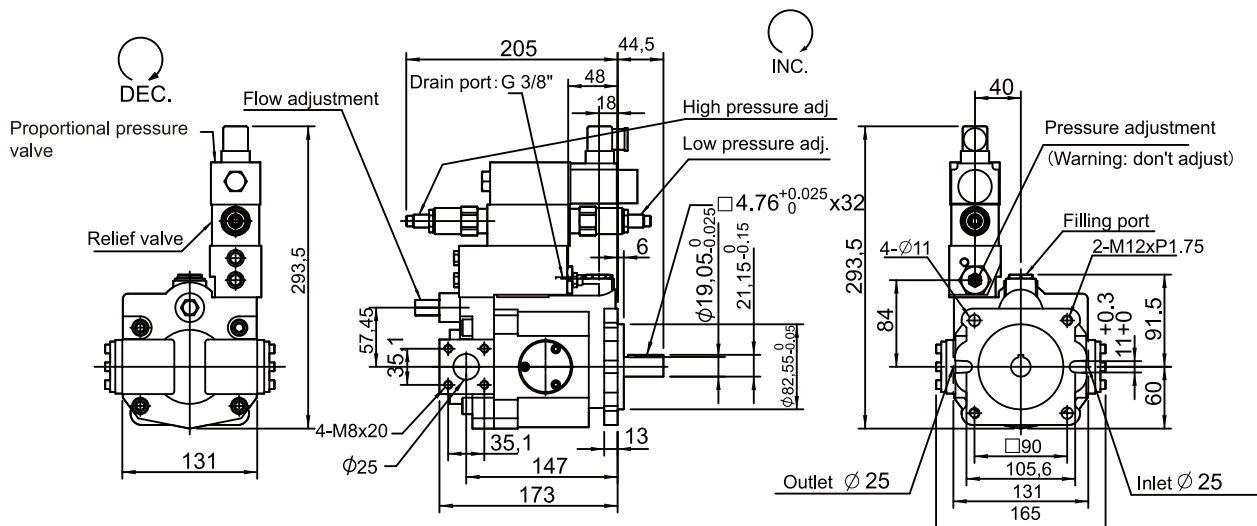





# Dimension

## V23A, V25A Standard pressure control

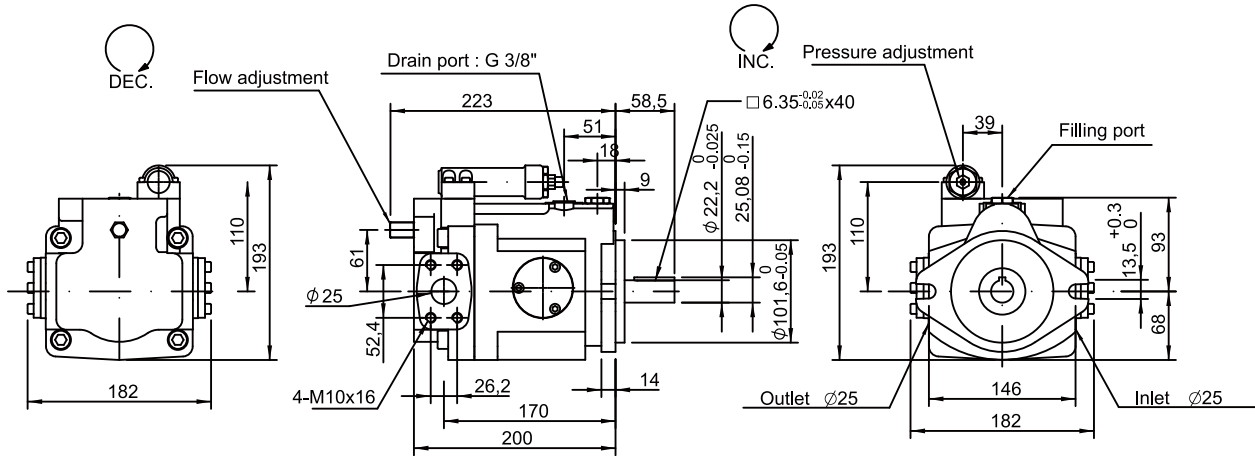

## V23G, V25G Remote pressure control

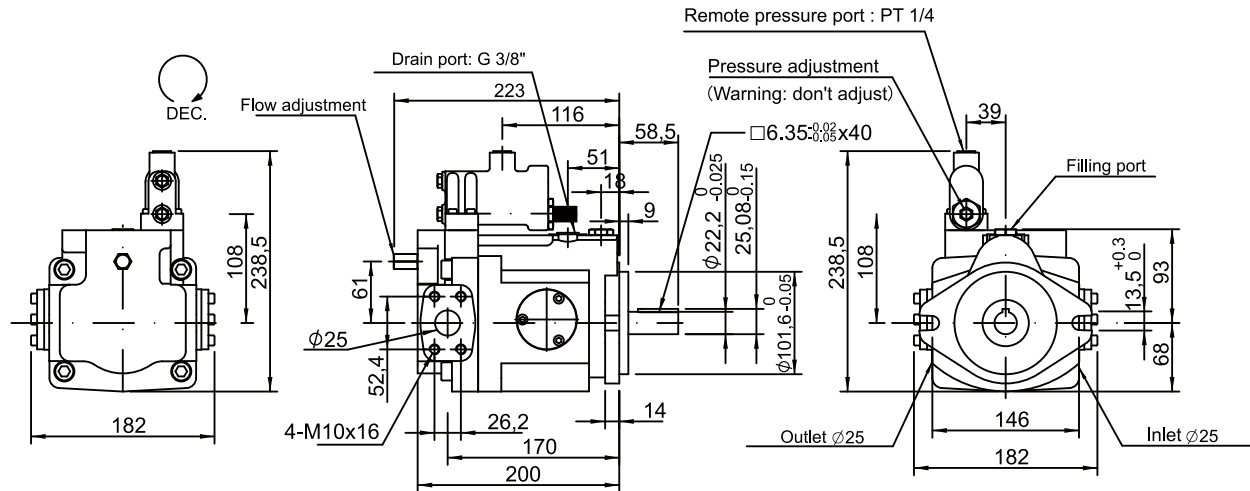

## V23HL, V25HL Load-sensing control

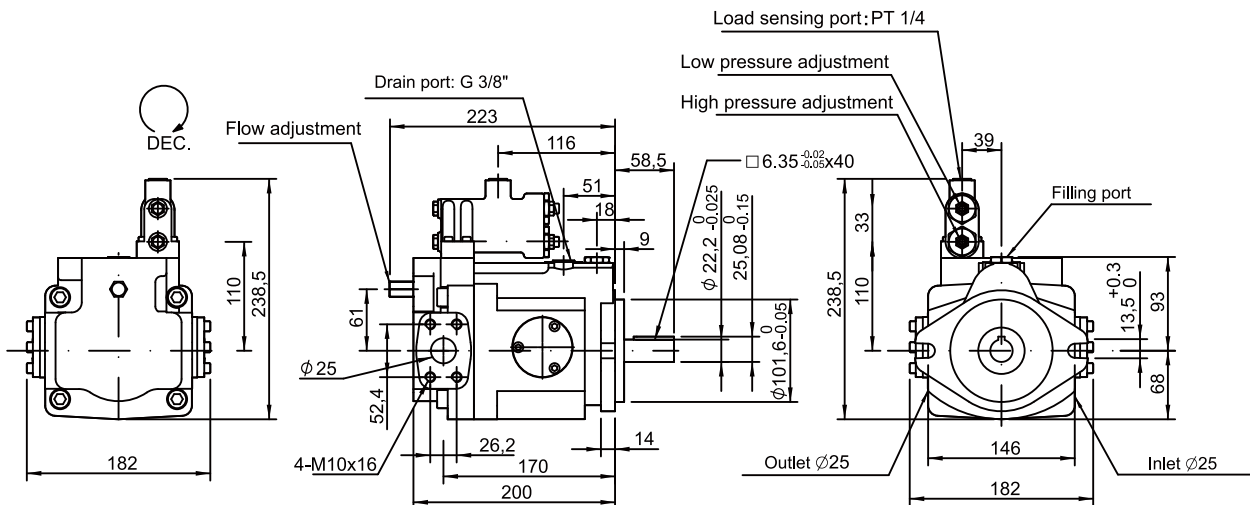



# Dimension

A

18

V Axial piston pump

V23B, V25B Multi-stage flow & Single-stage pressure control (with cylinder)

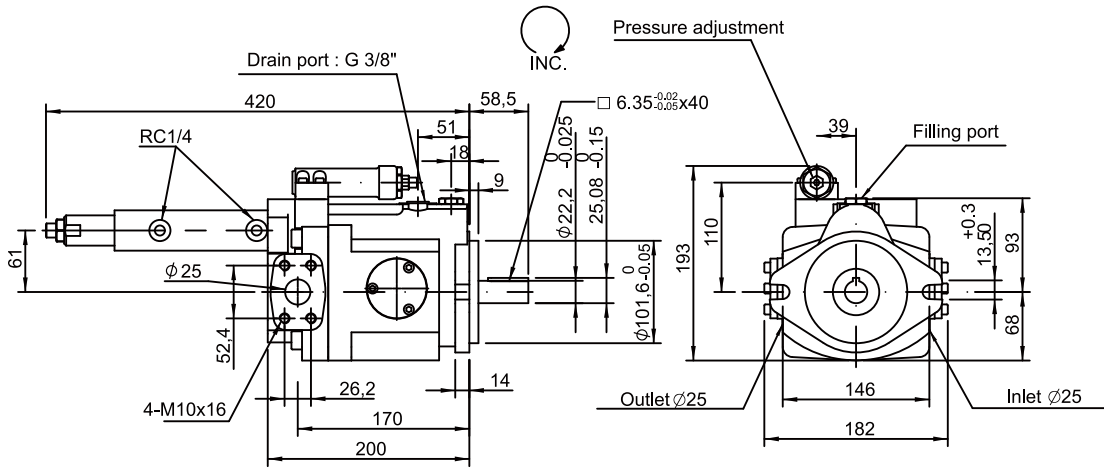

V23C, V25C 2-stage pressure & Flow control

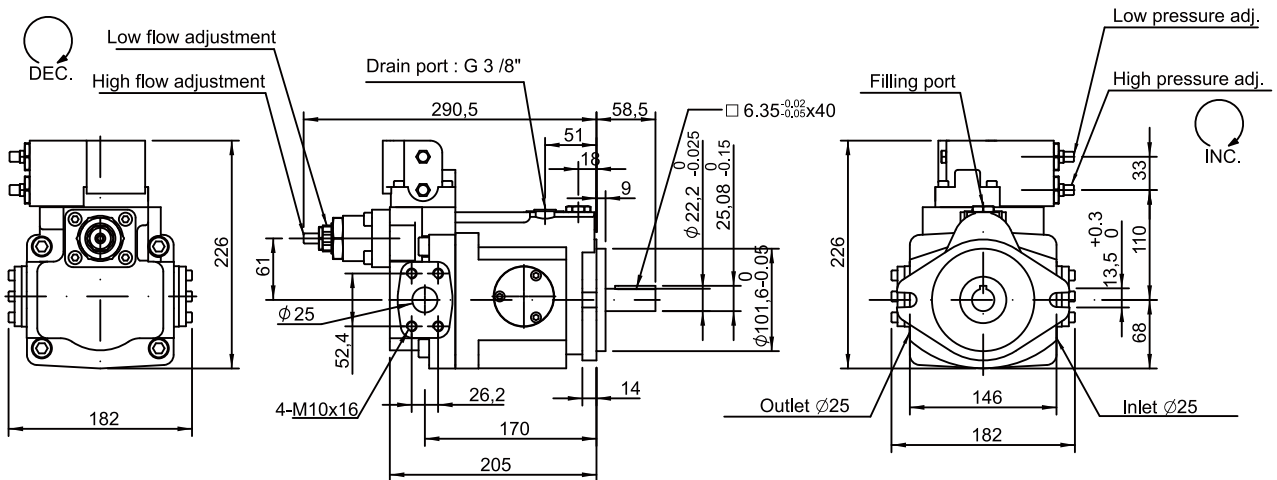

V23CG, V25CG 2-stage pressure & Flow control + Remote

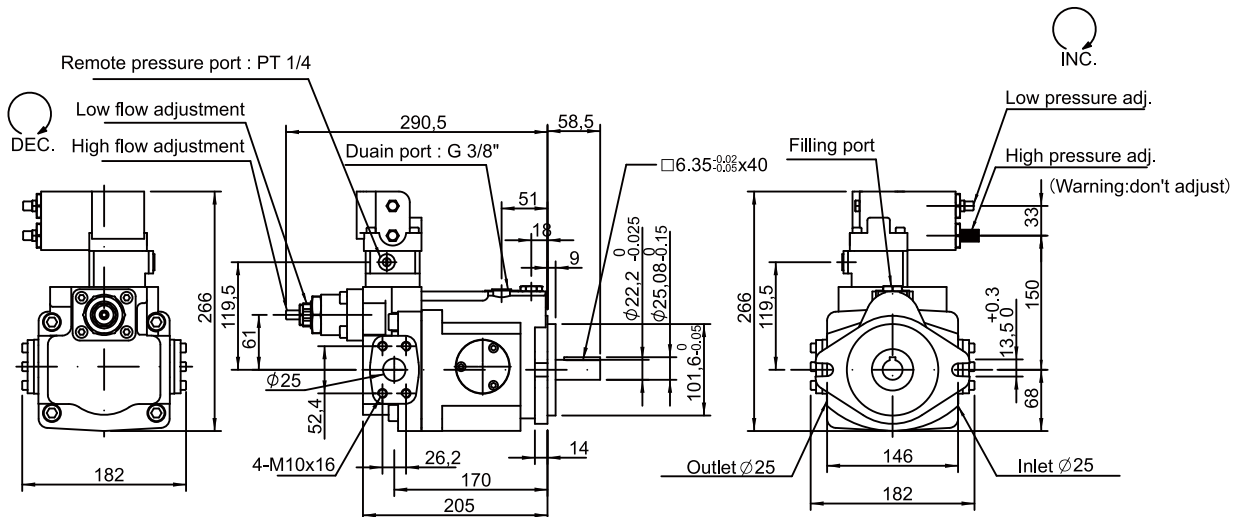

# Dimension

## V23CR, V25CR 2-stage pressure & Flow control + Low tension unloading

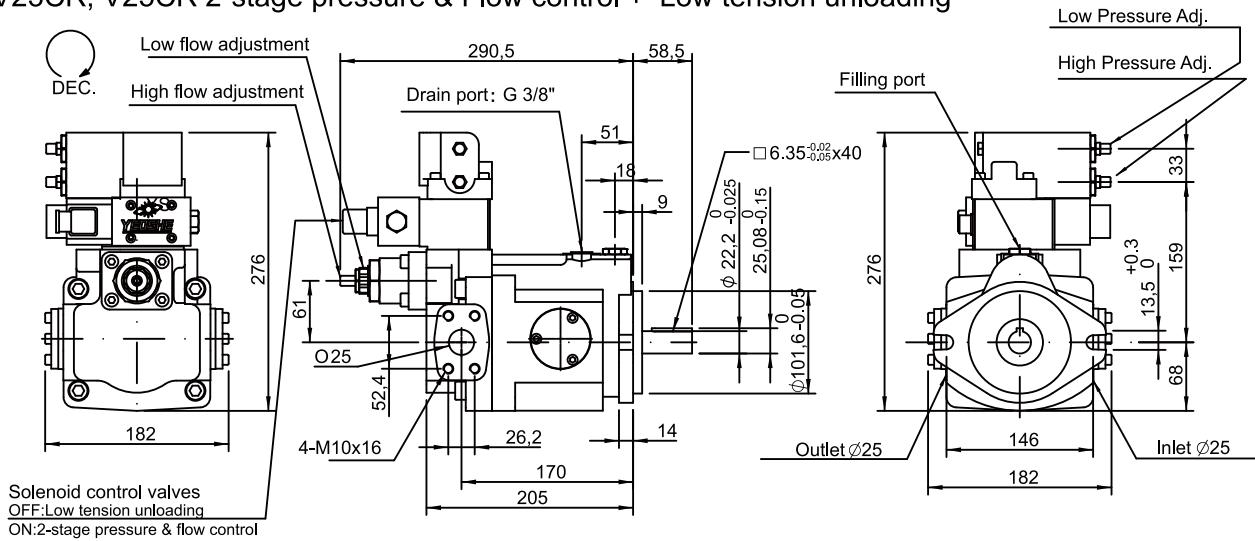

## V23D, V25D Low tension unloading + Pressure control

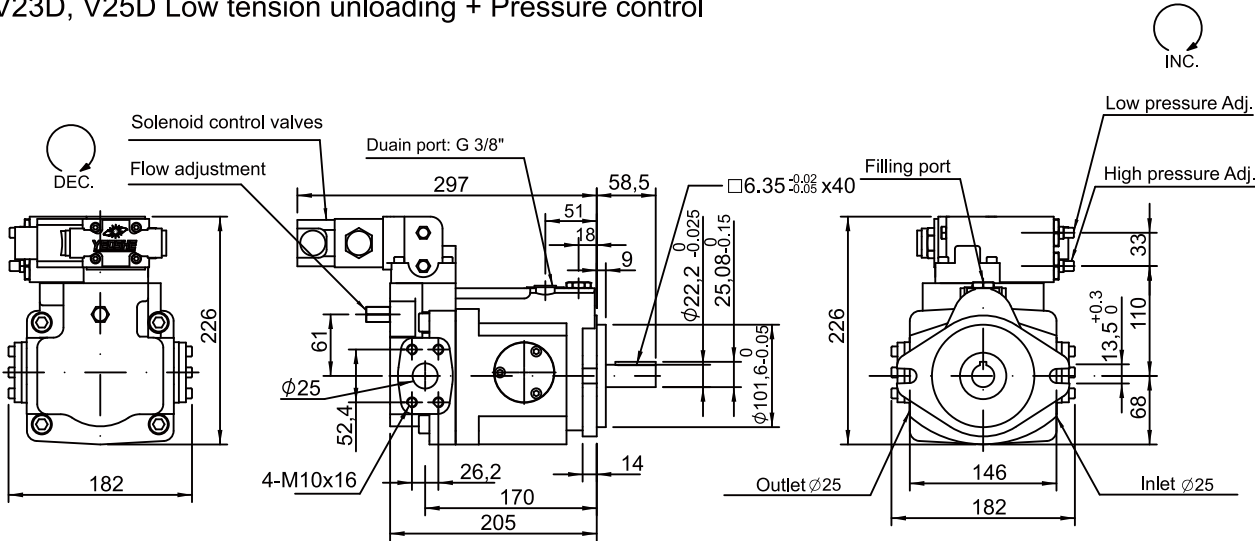

## V23DG, V25DG Low tension unloading + Pressure control + Remote

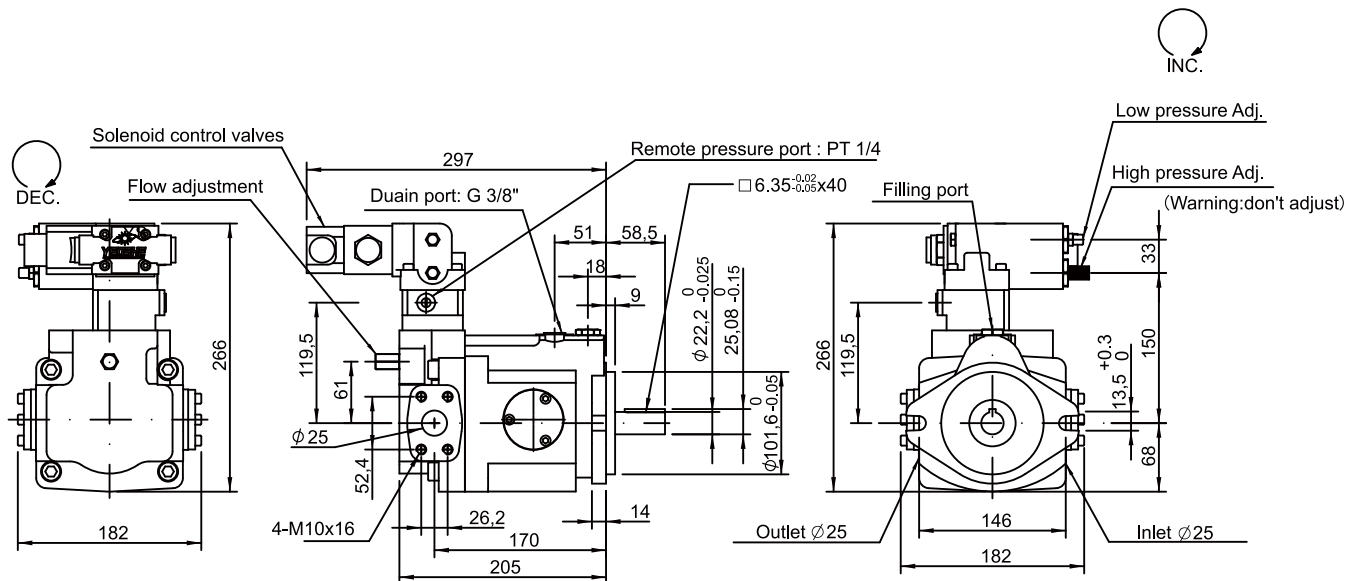



# Dimension

A

20

V Axial piston pump

V23E, V25E Electric 2-stage pressure control

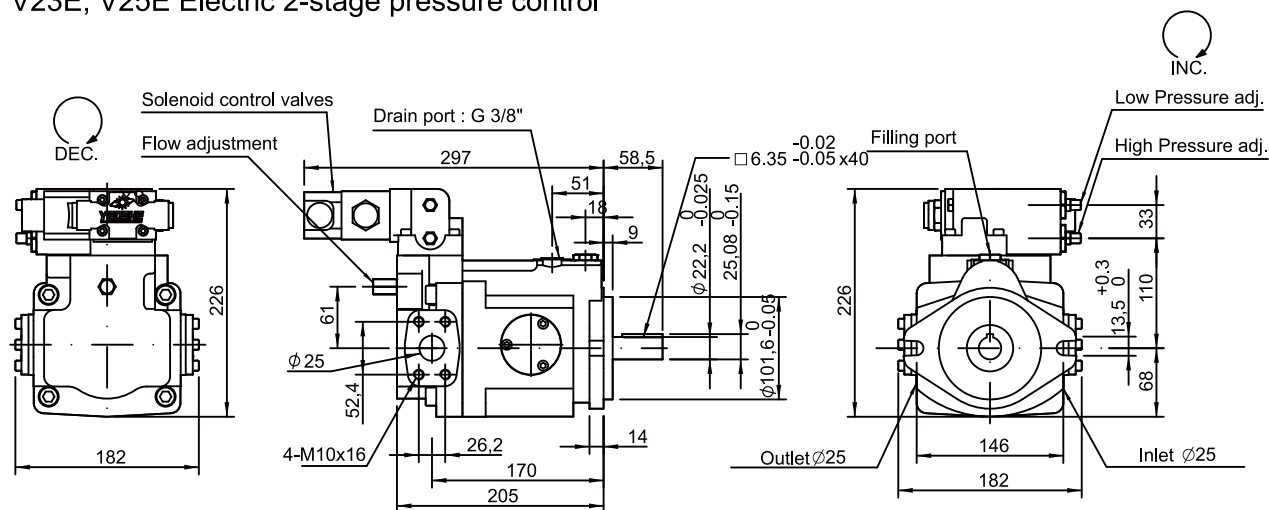

V23EG, V25EG Electric 2-stage pressure control + Remote

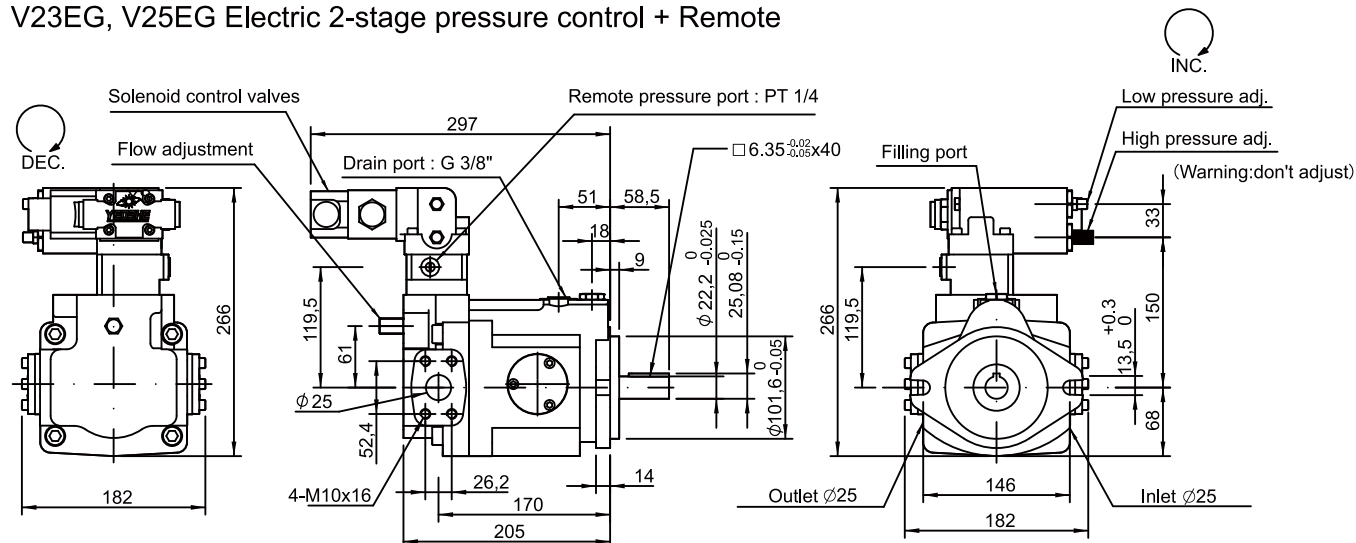

V23F, V25F Electric 2-stage pressure control & Flow control

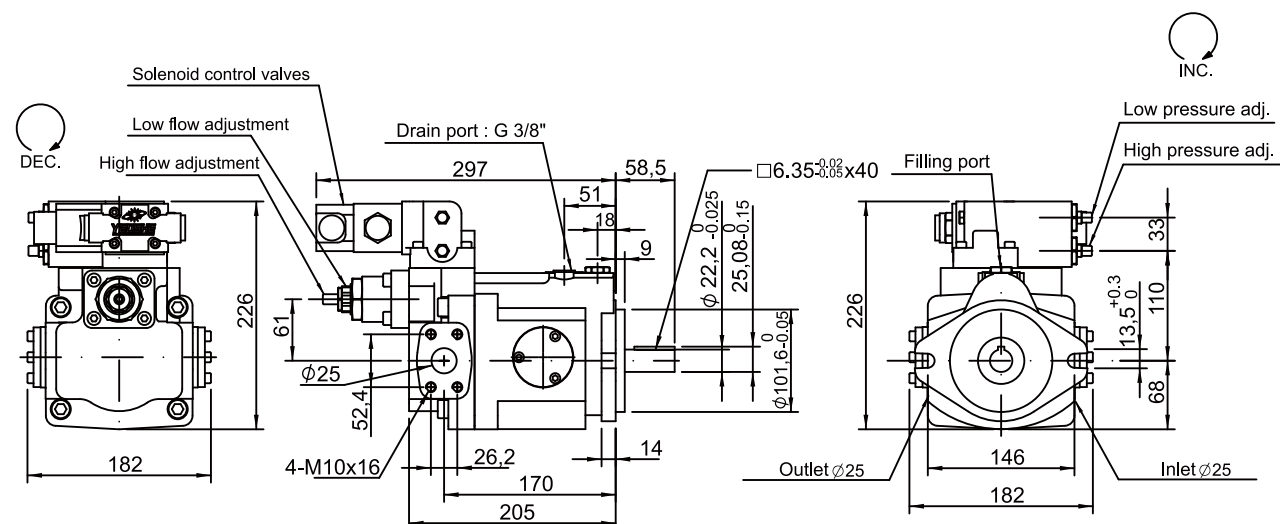

# Dimension

## V23FG, V25FG Electric 2-stage pressure control & Flow control + Remote

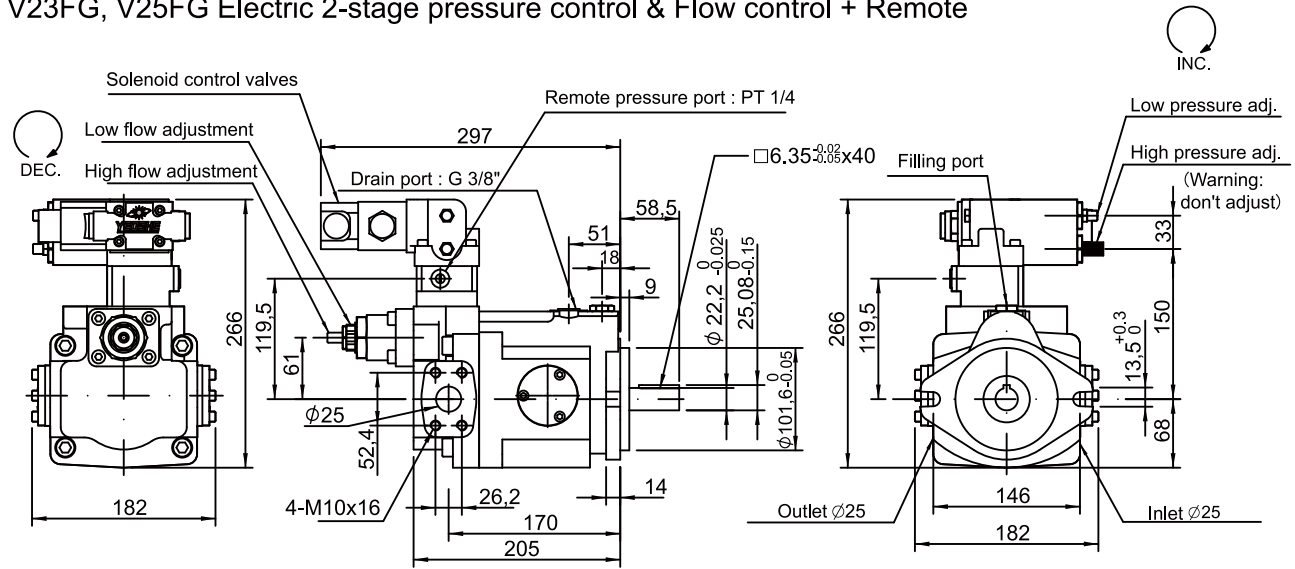

## V23GM, V25GM Remote pressure compensator with NG6 interface

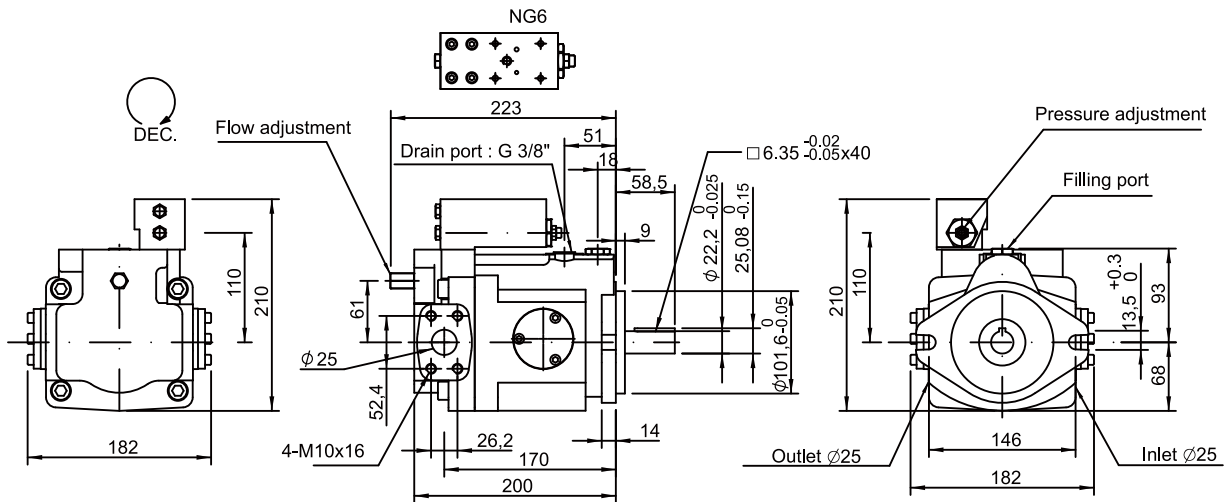

## V23GJ, V25GJ Remote pressure compensator + Proportional pressure valve

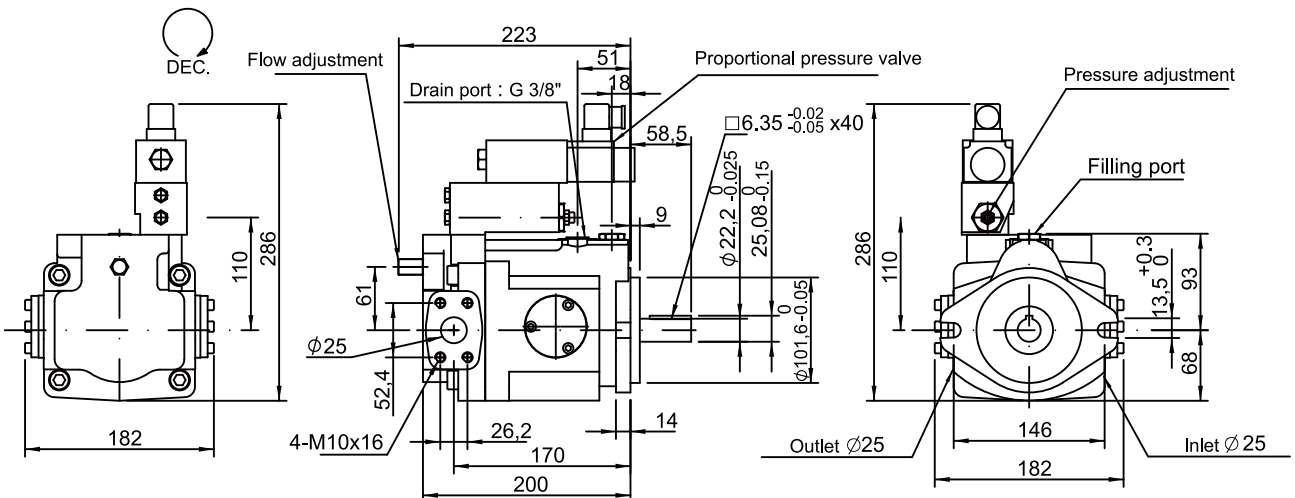







# Dimension

A

24

V Axial piston pump

V23, V25 Rear port ( Please flowing order code no.6,add"B" )

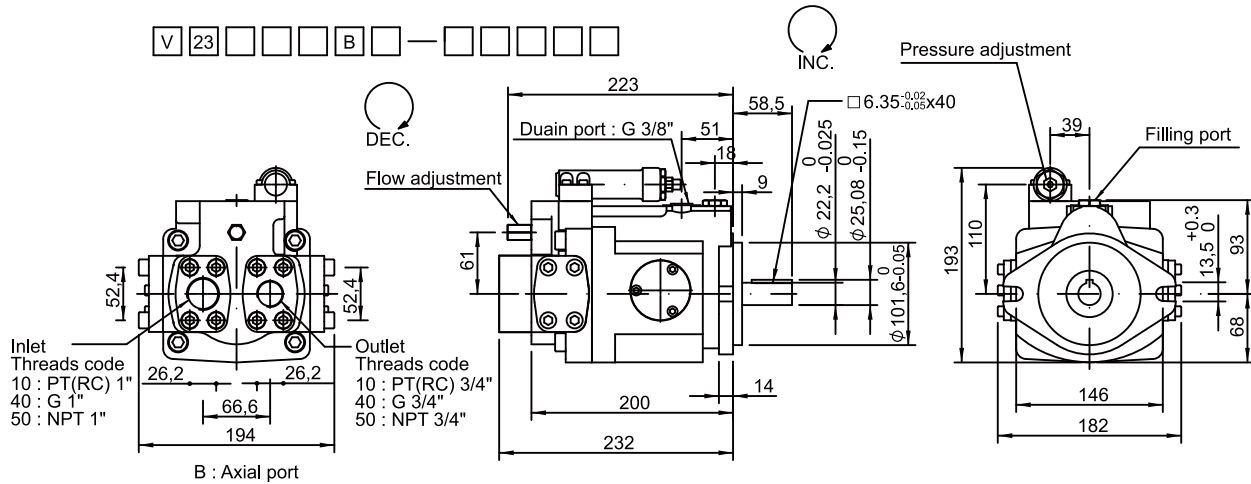

V23, V25 4 Connections for rear port ( Please flowing order code no.6,add"B2" )

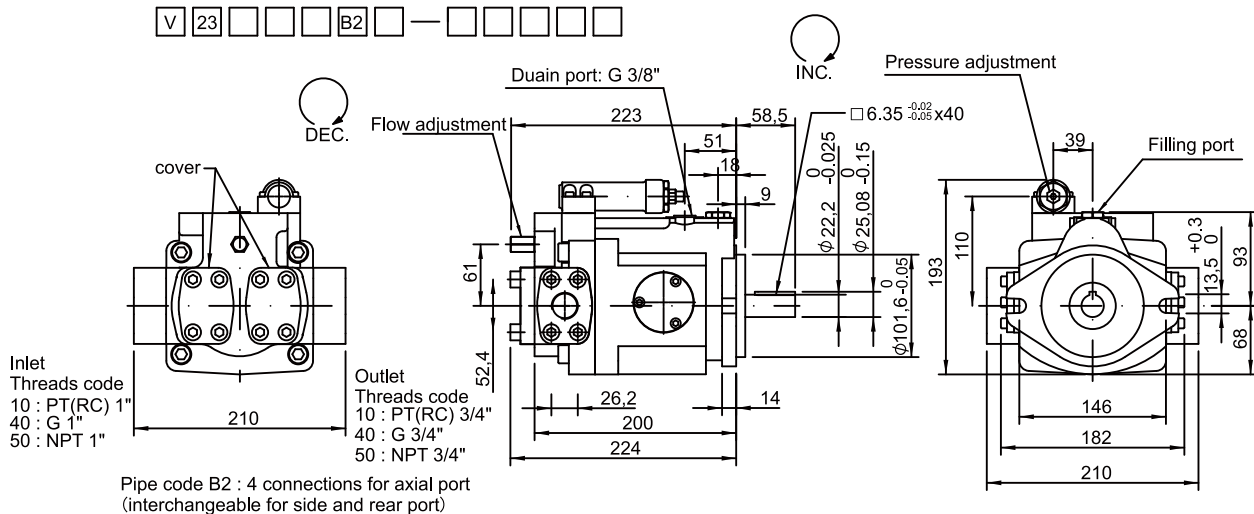

Type	A	B	C	CG	D	DG	E	EG	F	FG	G	GJ	GM	HL	HK	HQ
○ Axial port option	○	○									○	○	○	○		

V23, V25 Splined shaft type

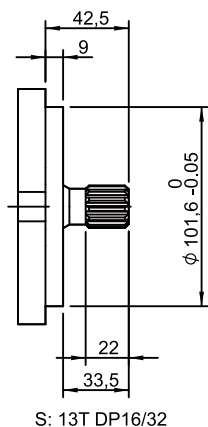

V23, V25 Inlet / Outlet

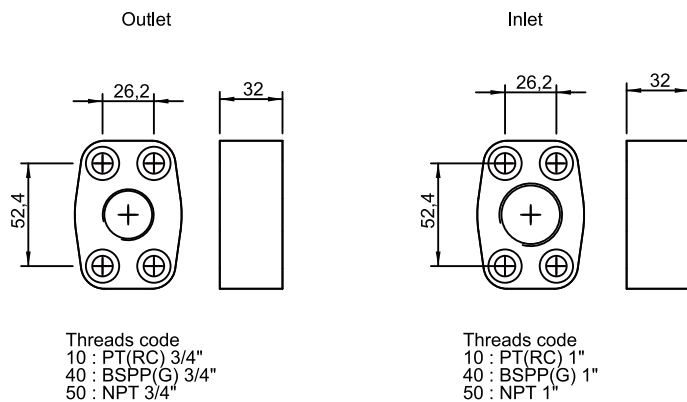

# Dimension

V38A, V42A Standard pressure control

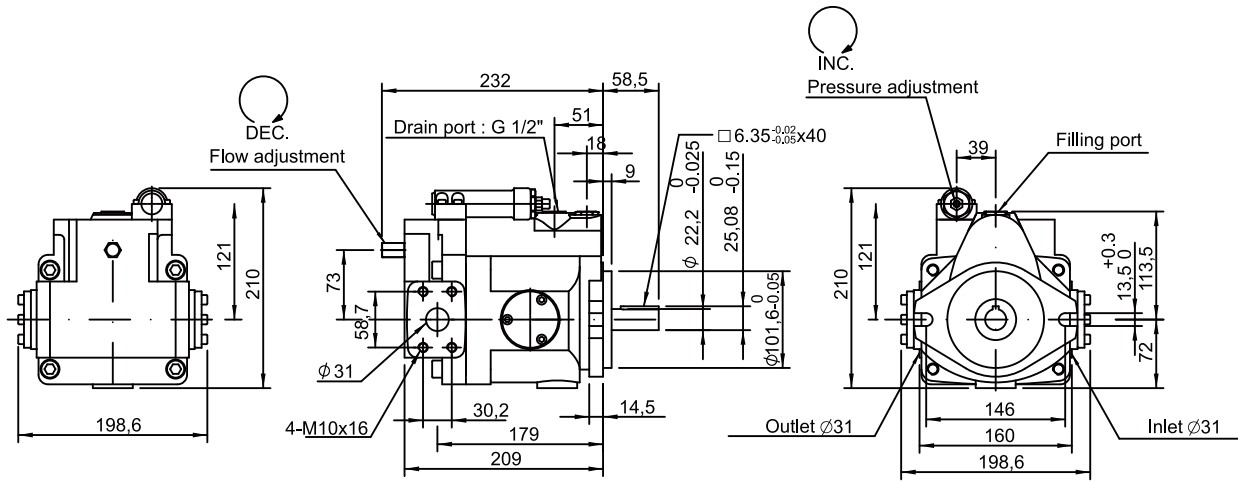

V38G, V42G Remote pressure control

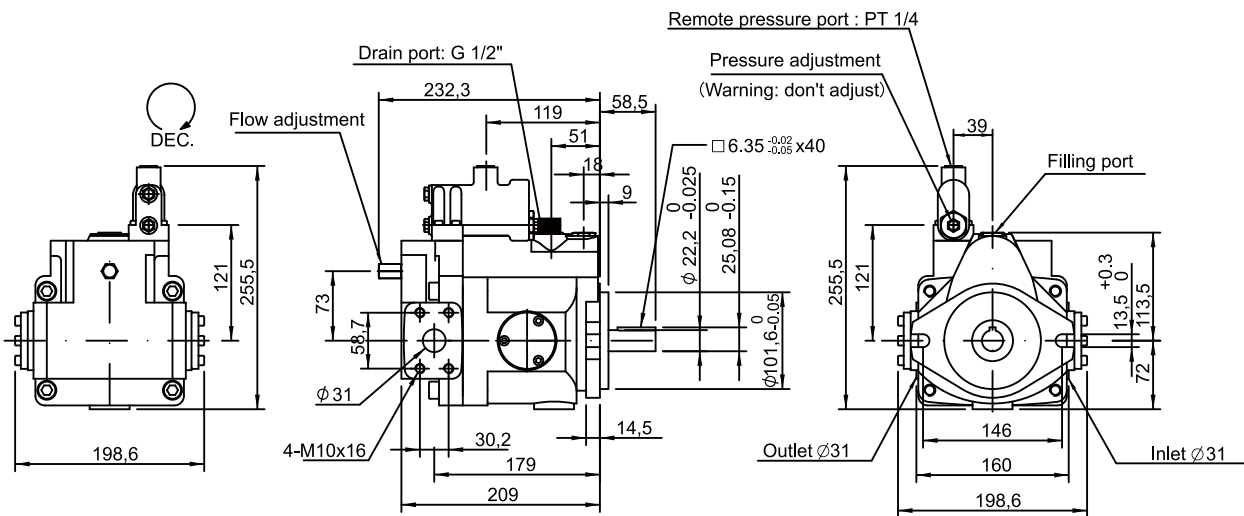

V38HL, V42HL Load-sensing control

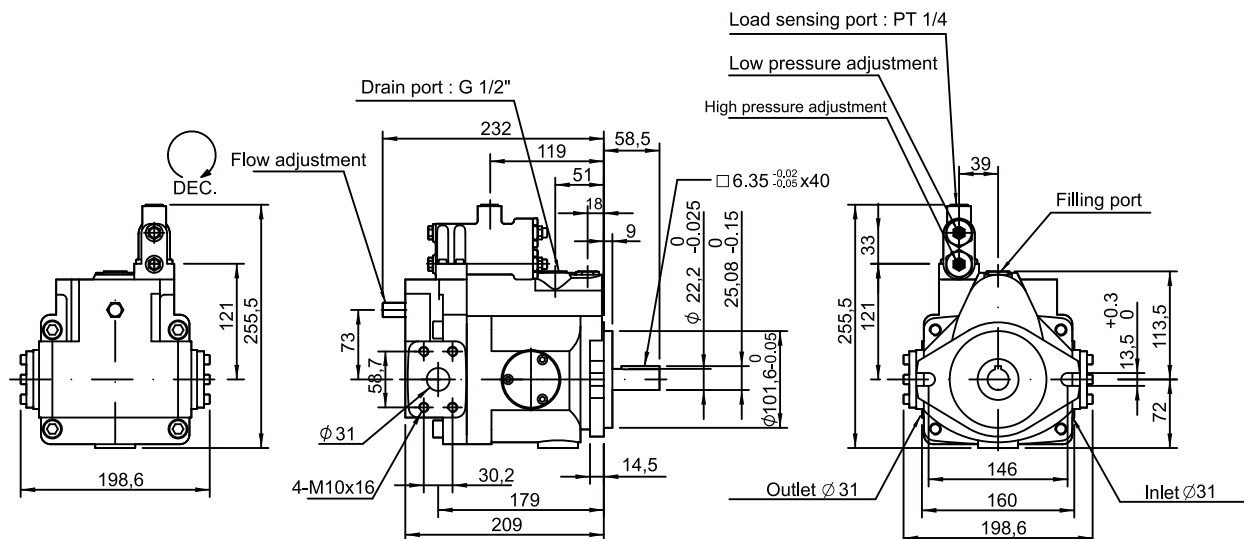



# Dimension

A

26

V Axial piston pump

## V38B, V42B Multi-stage flow & Single-stage pressure control (with cylinder)

(Remark: Install with A type control)

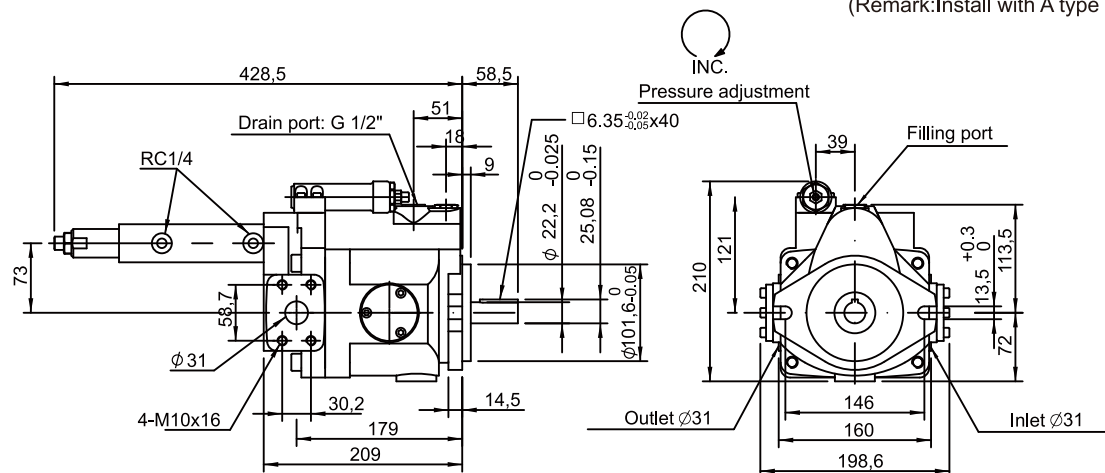

## V38C, V42C 2-stage pressure & Flow control

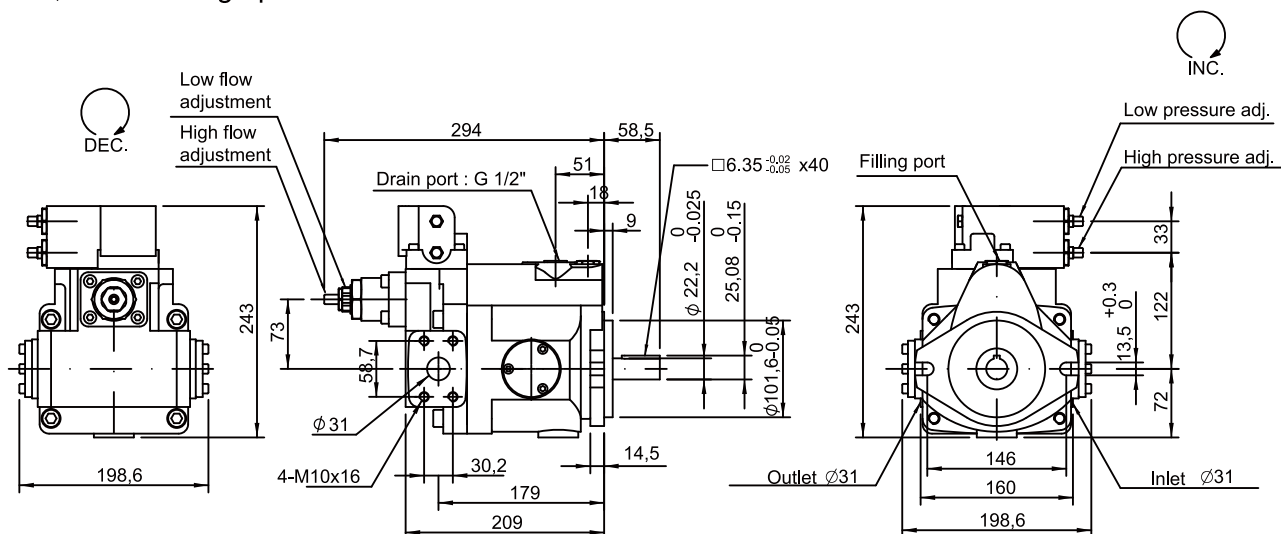

## V38CG, V42CG 2-stage pressure & Flow control + Remote

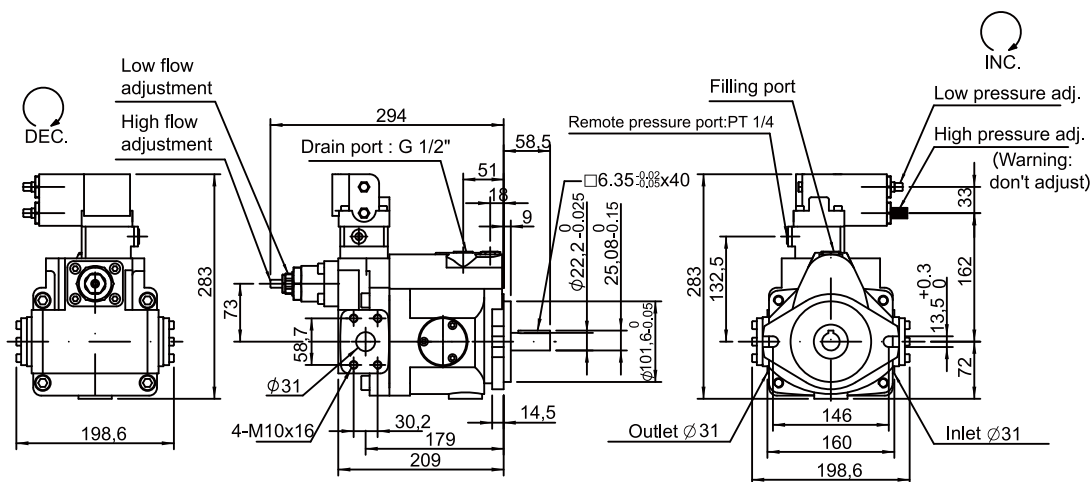

# Dimension

## V38CR, V42CR 2-stage pressure & Flow control + Low tension unloading

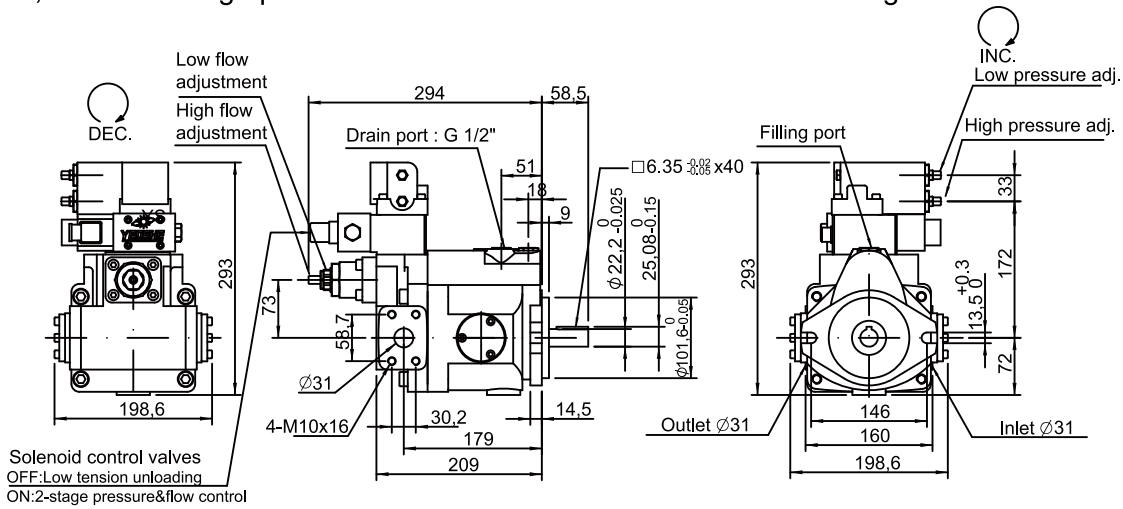

## V38D, V42D Low tension unloading + Pressure control

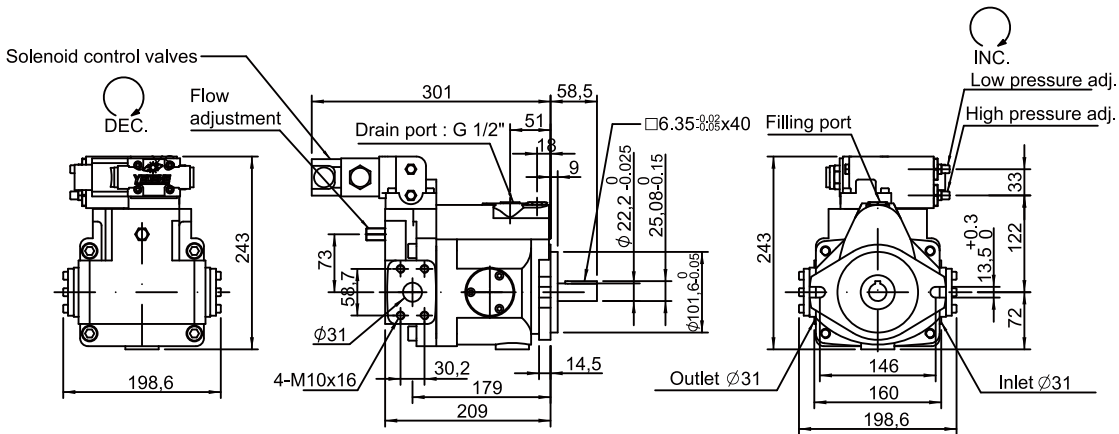

## V38DG, V42DG Low tension unloading + Pressure control + Remote

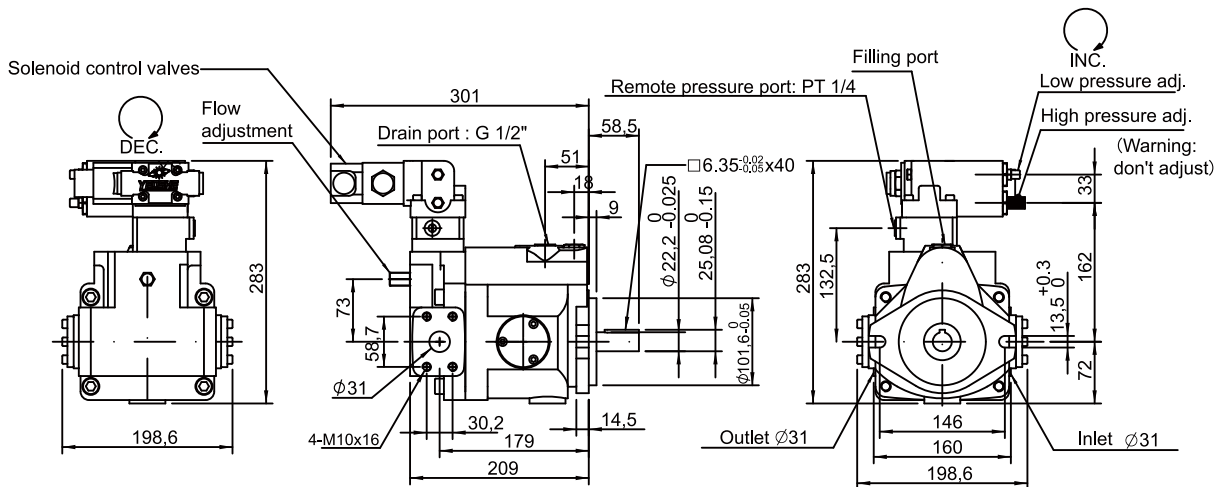



# Dimension

A

28

V Axial piston pump

V38E, V42E Electric 2-stage pressure control

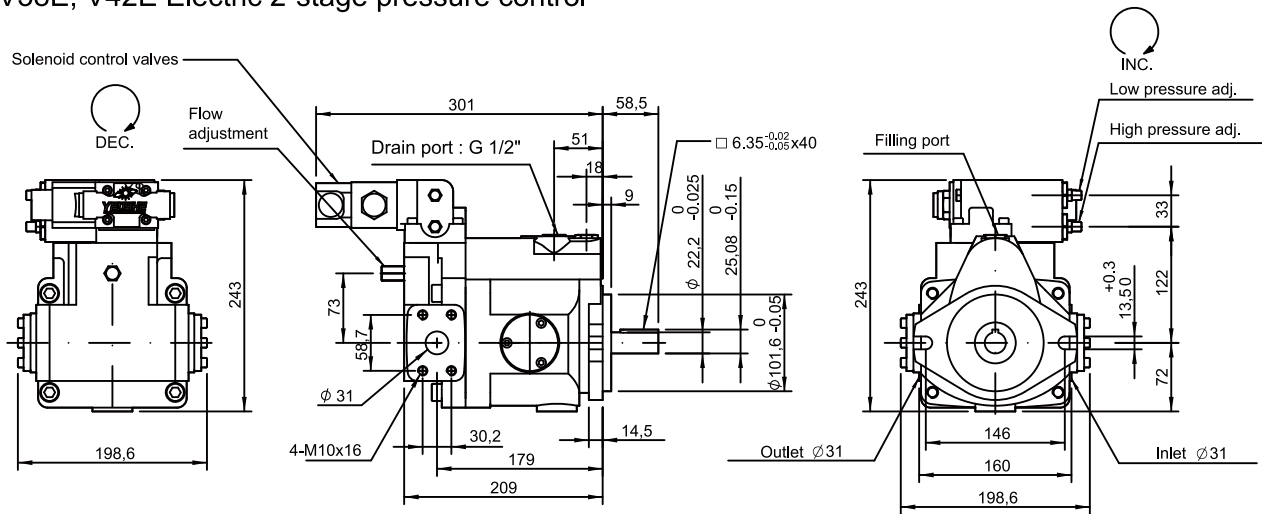

V38EG, V42EG Electric 2-stage pressure control + Remote

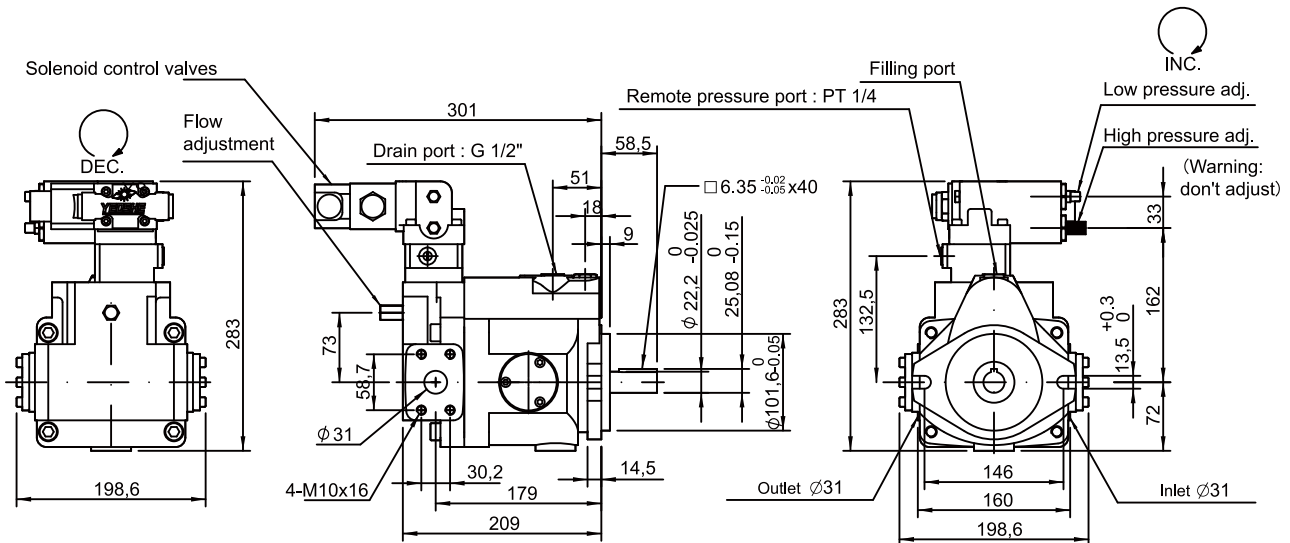

V38F, V42F Electric 2-stage pressure control & Flow control

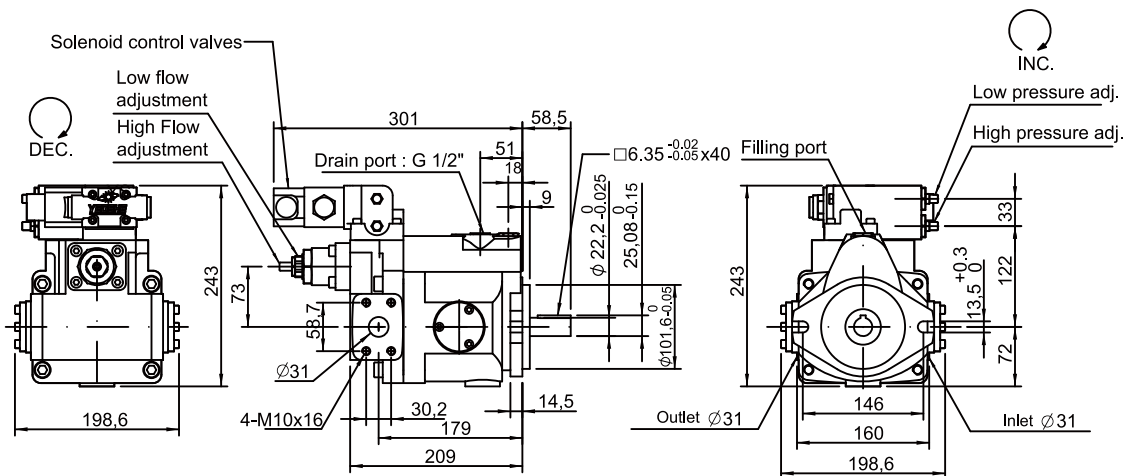

# Dimension

V38FG, V42FG Electric 2-stage pressure control & Flow control + Remote

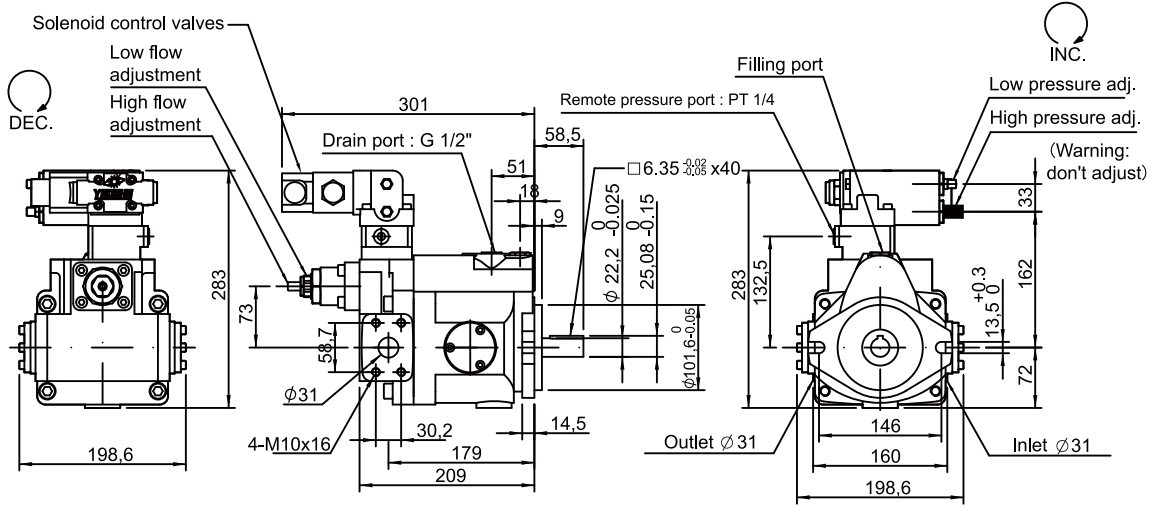

V38GM, V42GM Remote pressure compensator with NG6 interface

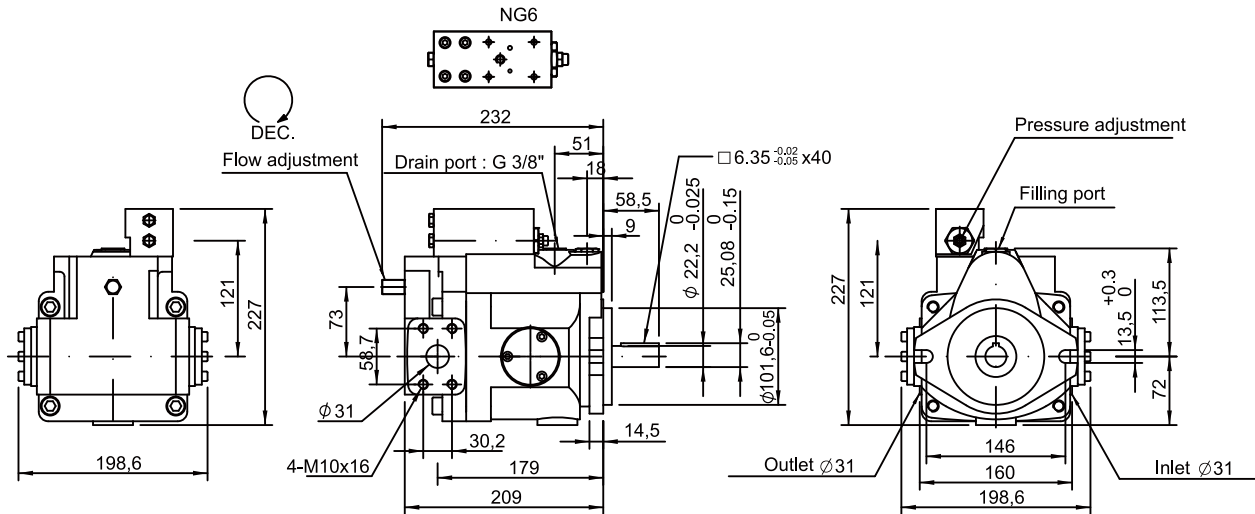

V38GJ, V42GJ Remote pressure compensator + Proportional pressure valve

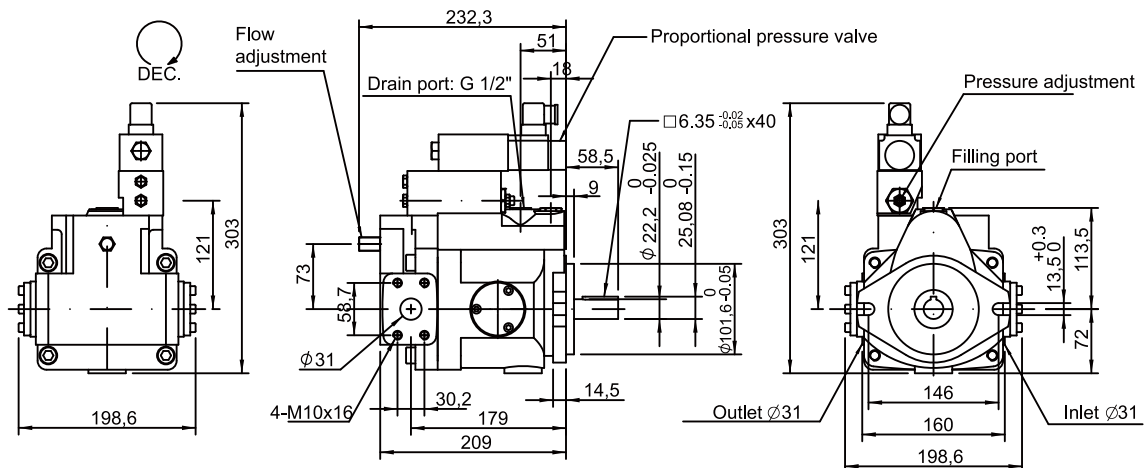



# Dimension

A

30

V Axial piston pump

V38GR, V42GR Remote pressure compensator + Electrical unloading

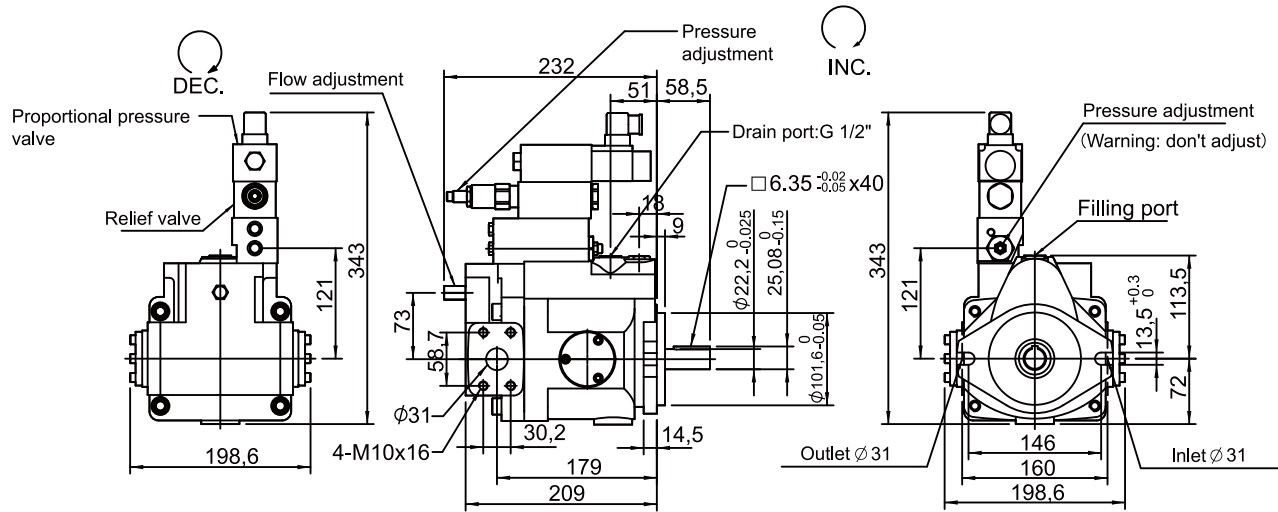

V38GB, V42GB Remote pressure compensator + 2-stage pressure control

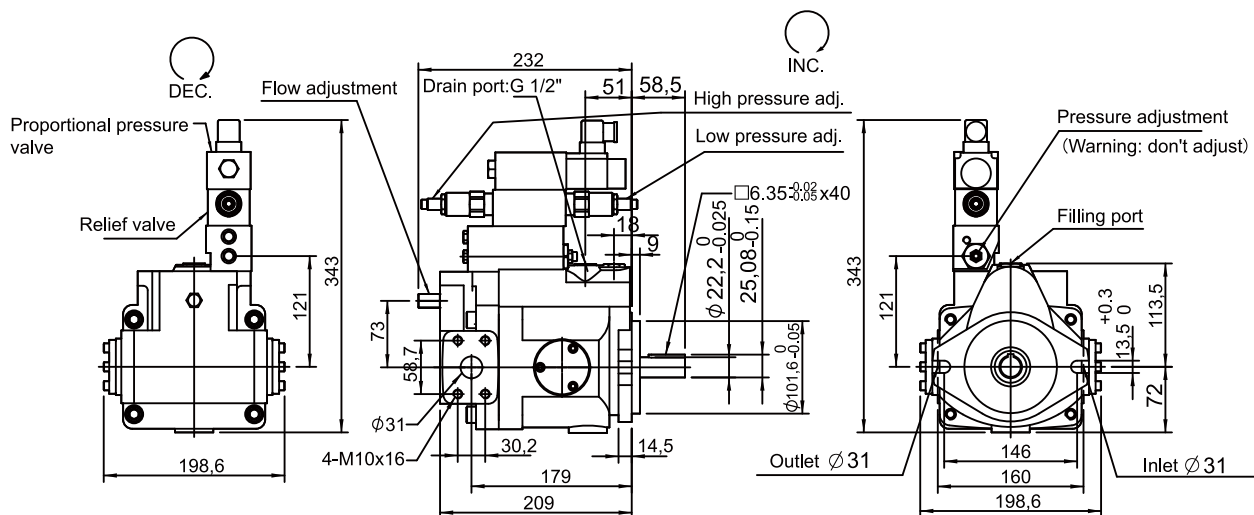

V38GC, V42GC Remote pressure compensator + Electrical unloading + 2-stage pressure control

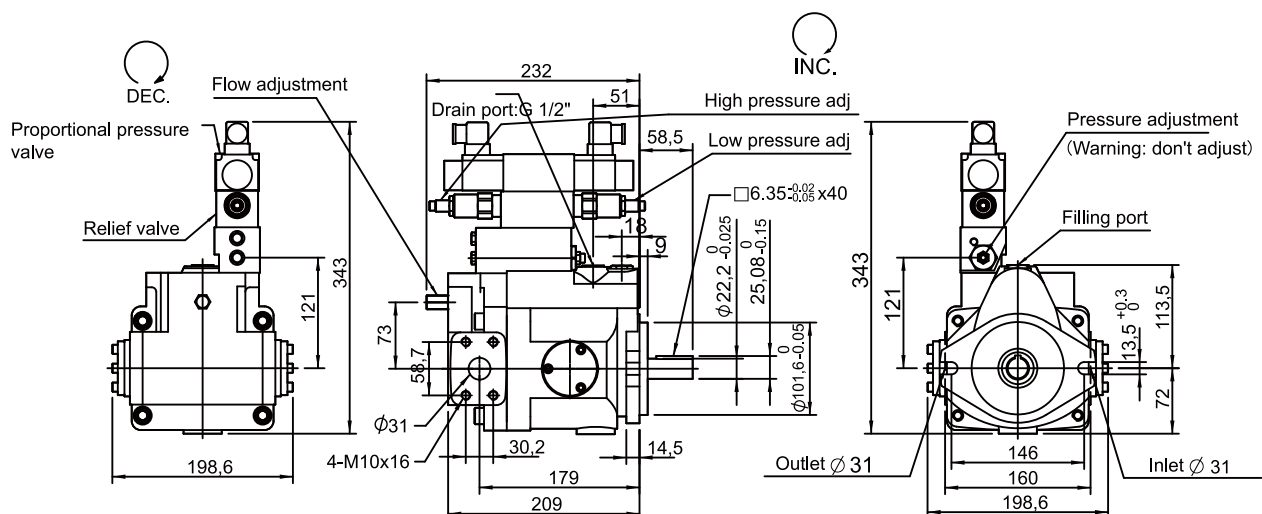





# Dimension

A

32

V Axial piston pump

V38, V42 Rear port ( Please following order code no.6,add“B” )

V 38 □ □ □ B □ — □ □ □ □ □ □

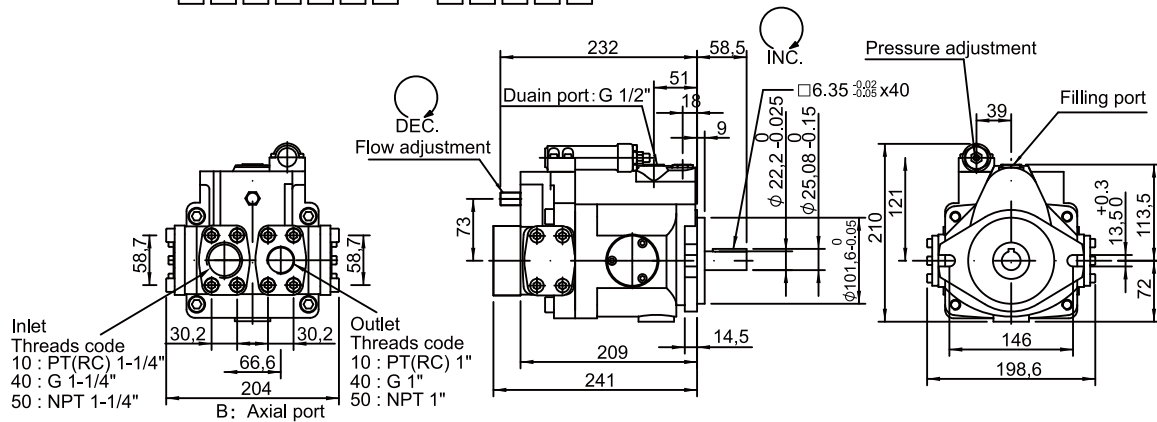

V38, V42 4 connections for rear port ( Please following order code no.6,add“B2” )

V 38 □ □ □ B2 □ — □ □ □ □ □ □

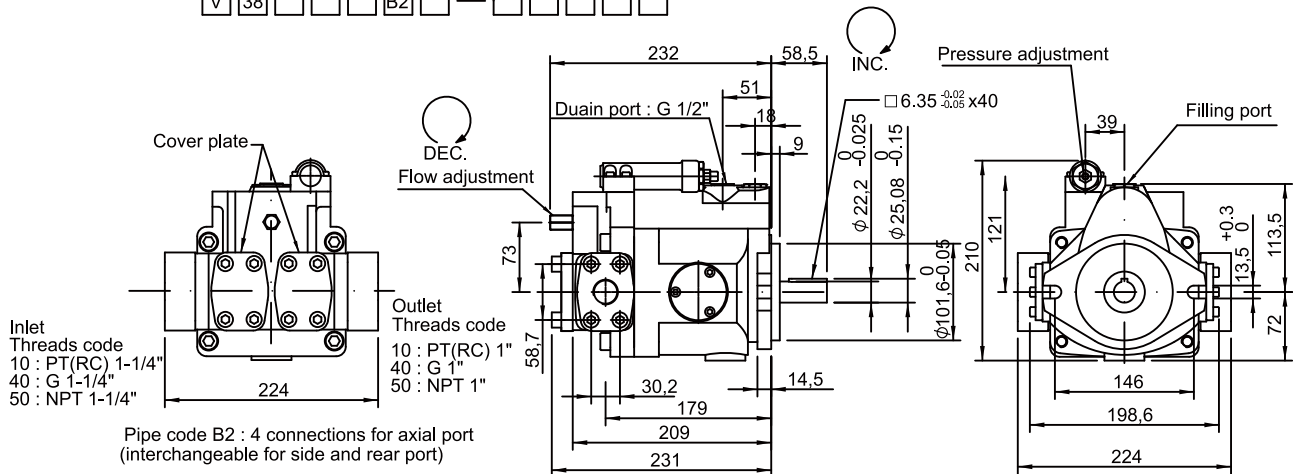

Type	A	B	C	CG	D	DG	E	EG	F	FG	G	GJ	GM	HL	HK	HQ
○ Axial port option	○	○	○	○					○	○	○	○	○	○		

V38, V42 Splined shaft type

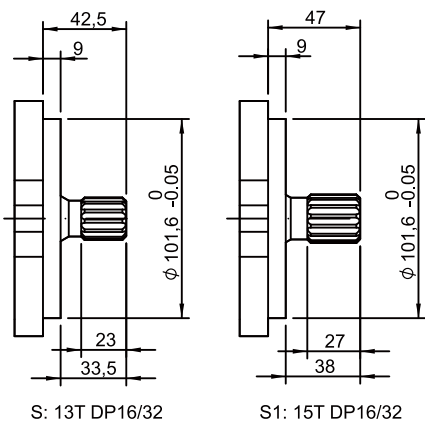

V38, V42 Inlet / Outlet

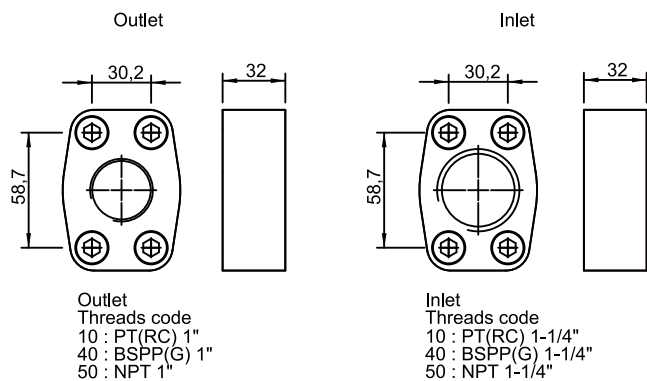

# Dimension

## V50A, V70A Standard pressure control

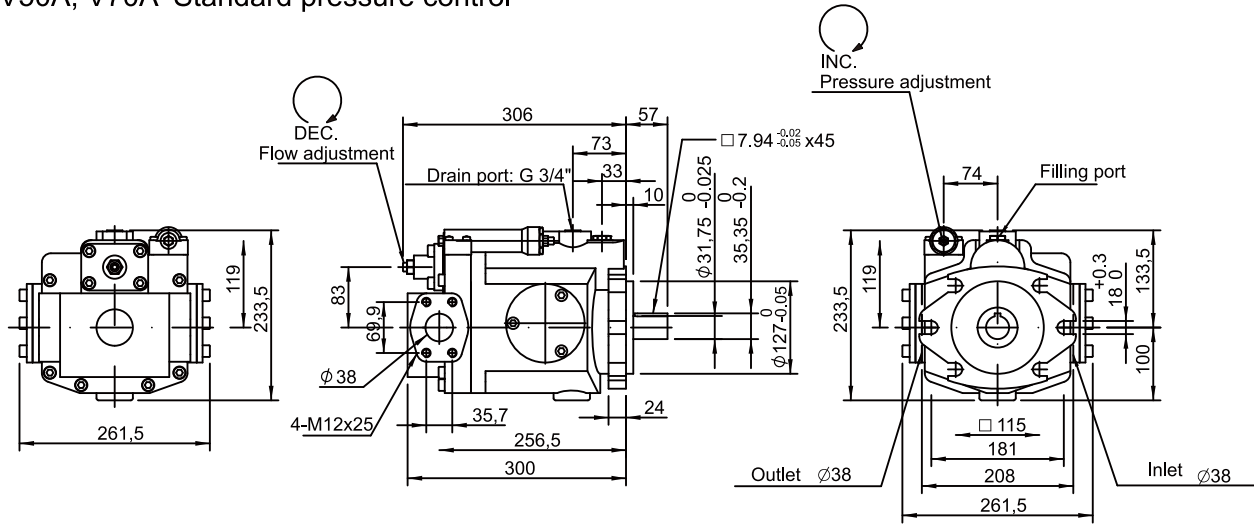

## V50G, V70G Remote pressure control

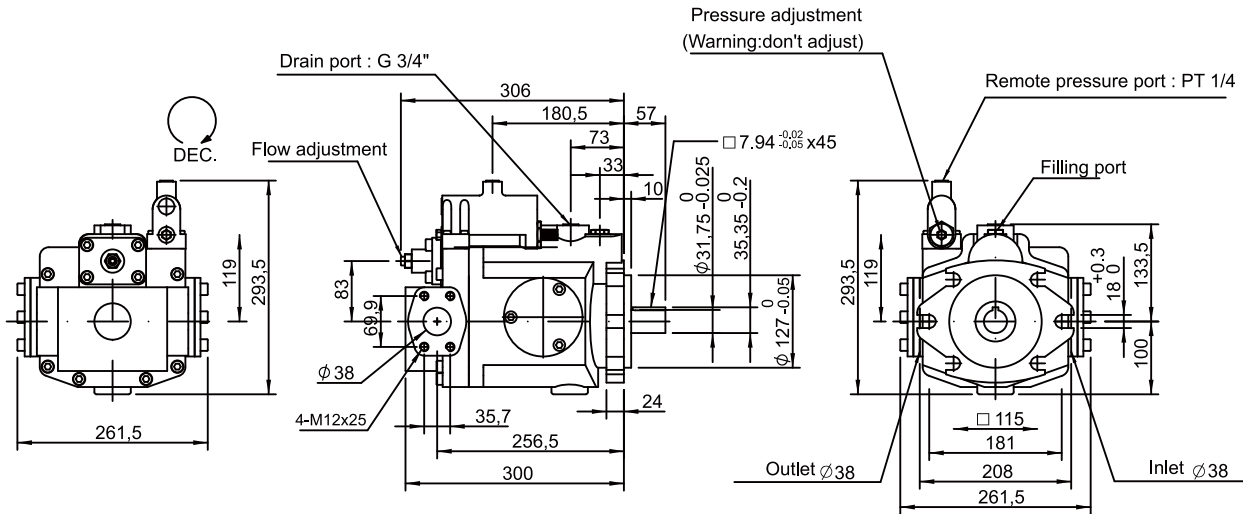

## V50HL, V70HL Load-sensing control

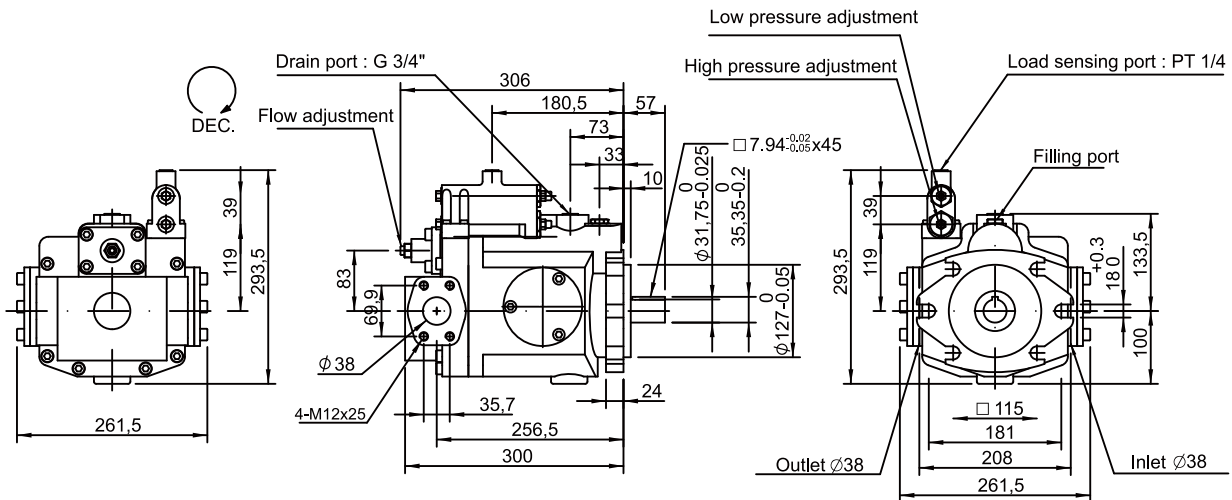



# Dimension

A

34

V Axial piston pump

## V50B, V70B Multi-stage flow & Singe-stage pressure control (with cylinder)

(Remark: Install with A type control)

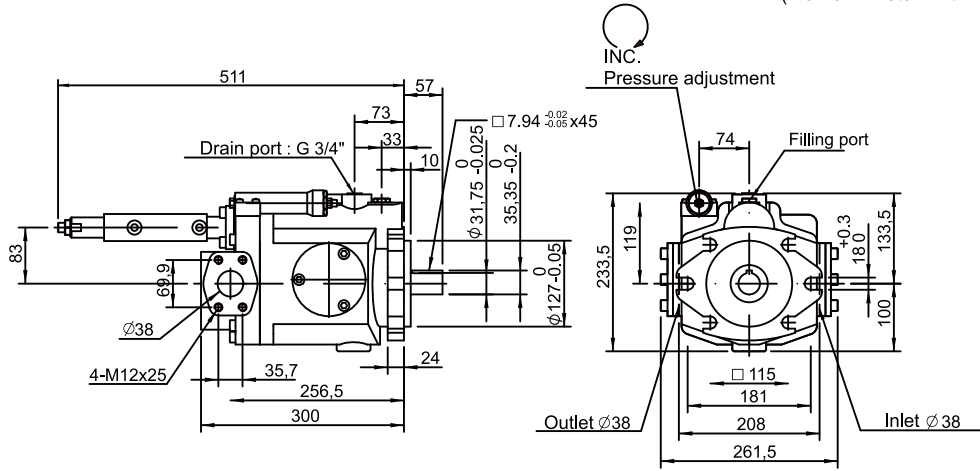

## V50C, V70C 2-stage pressure & Flow control

## V50CG, V70CG 2-stage pressure & Flow control + Remote

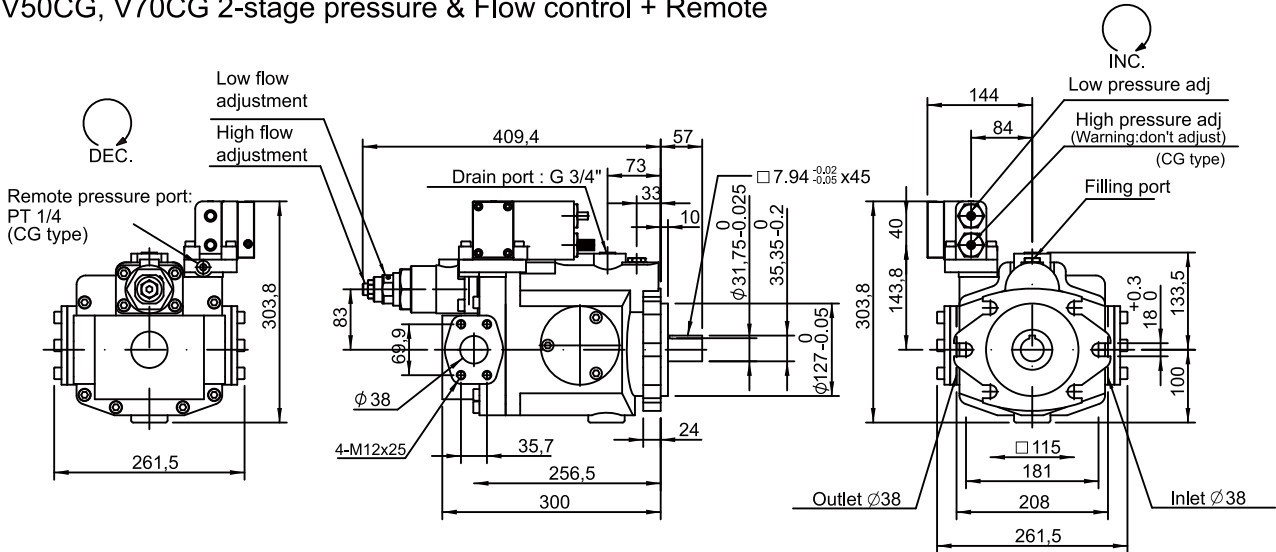

## V50CR, V50CR 2-stage pressure & Flow control + Low tension unloading

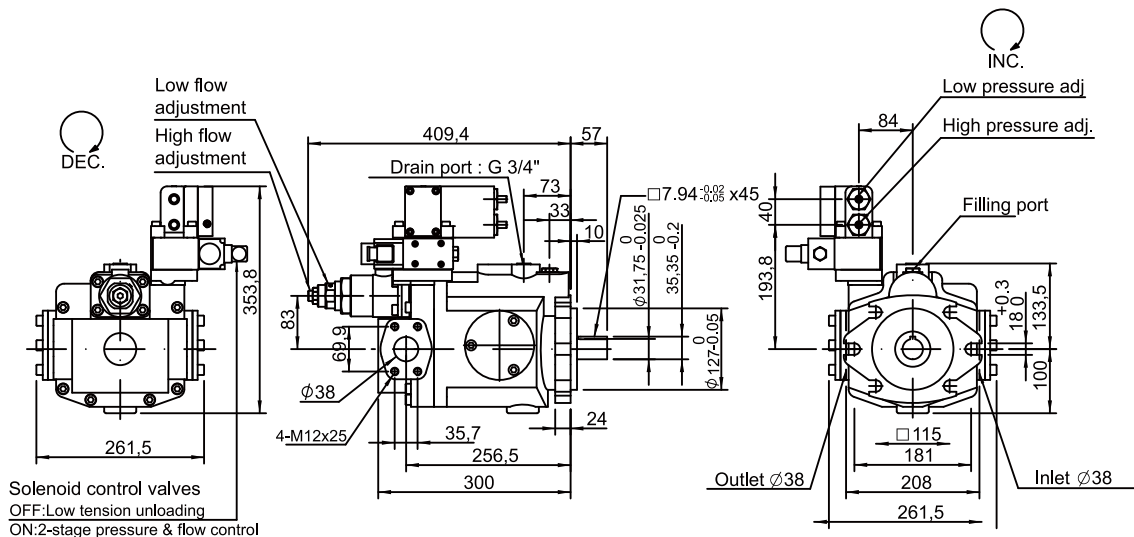

# Dimension

V50D, V70D Low tension unloading + Pressure control  
 V50DG, V70DG Low tension unloading + Pressure control + Remote

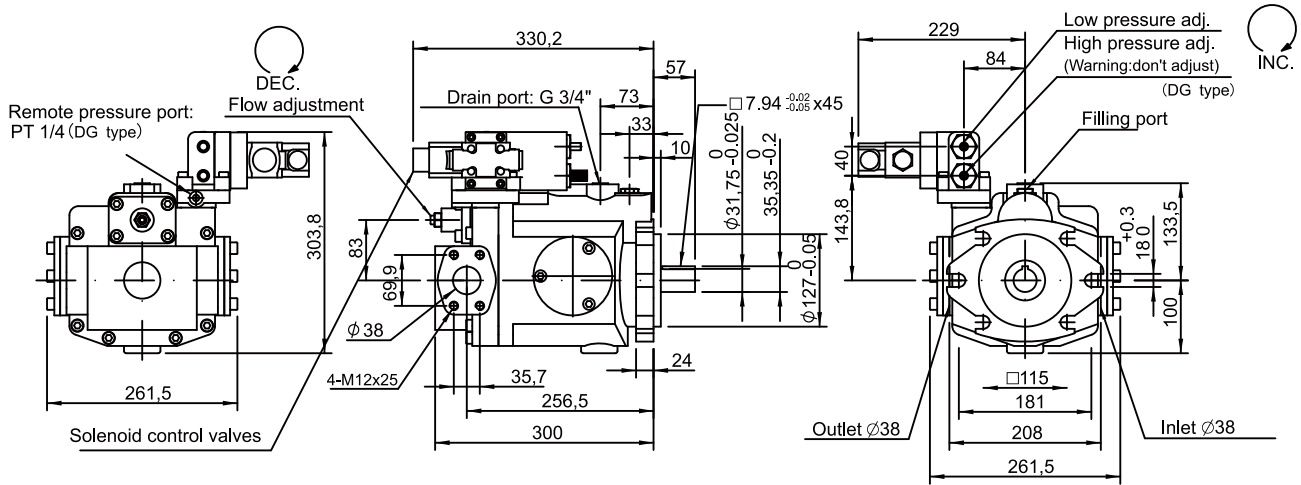

V50E, V70E Electric 2-stage pressure control  
 V50EG, V70 EG Electric 2-stage pressure control + Remote

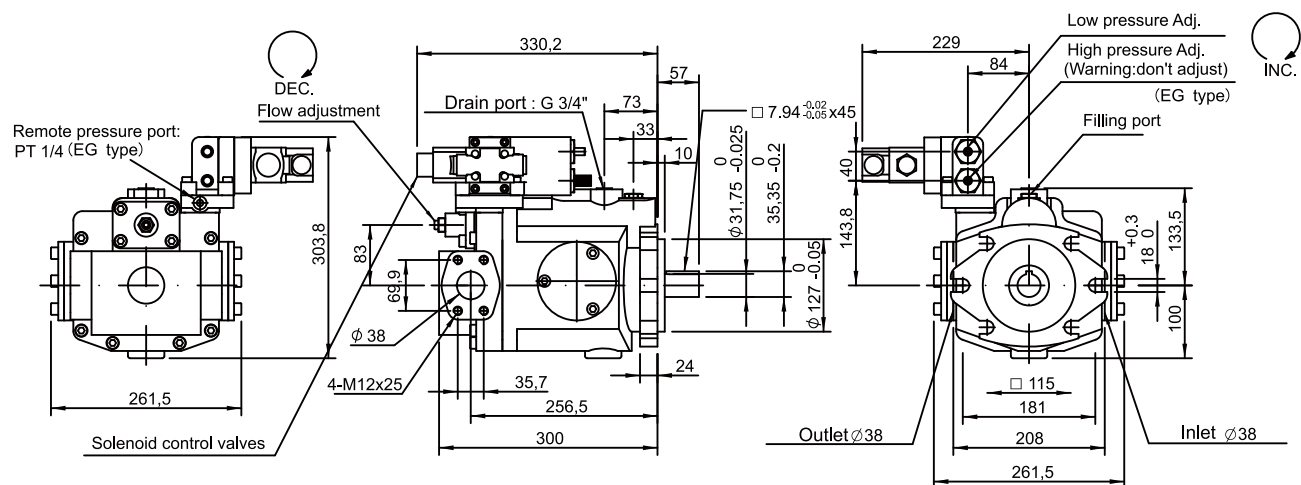

V50F, V70F Electric 2-stage pressure control & Flow control  
 V50FG, V70 Electric 2-stage pressure control & Flow control + Remote

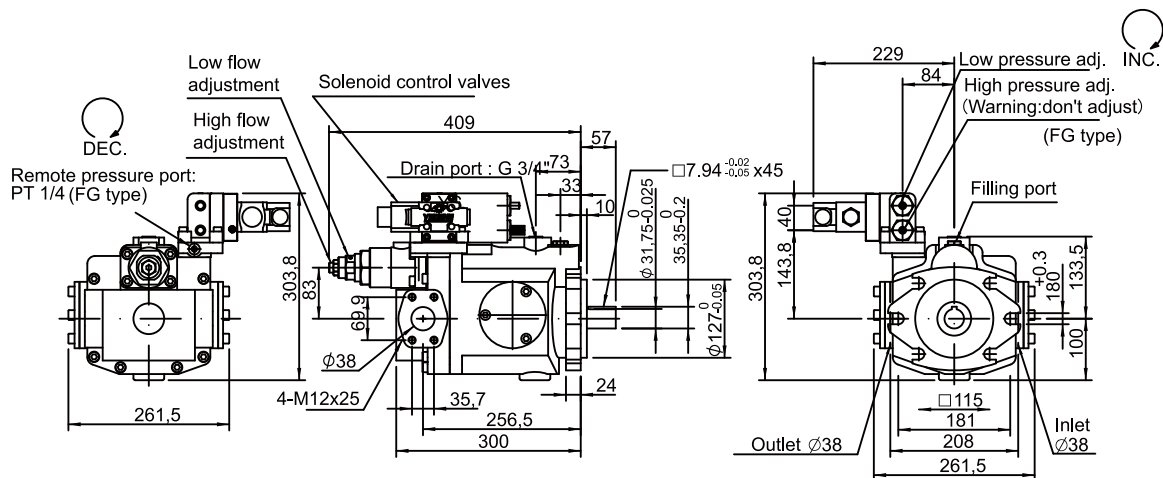

# Dimension

A

36

V Axial piston pump

V50GM, V70GM Remote pressure compensator with NG6 interface

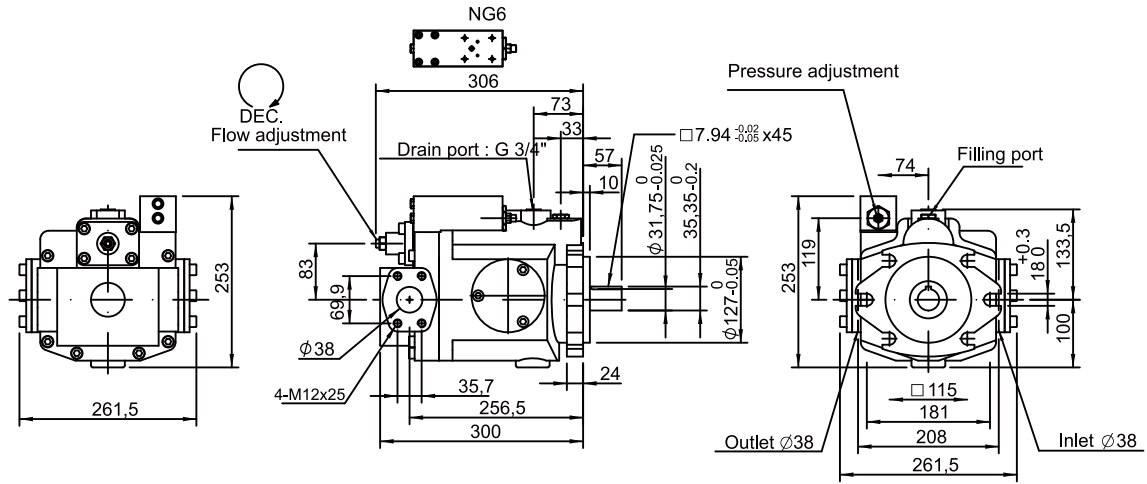

V50GJ, V70GJ Remote pressure compensator + Proportional pressure valve

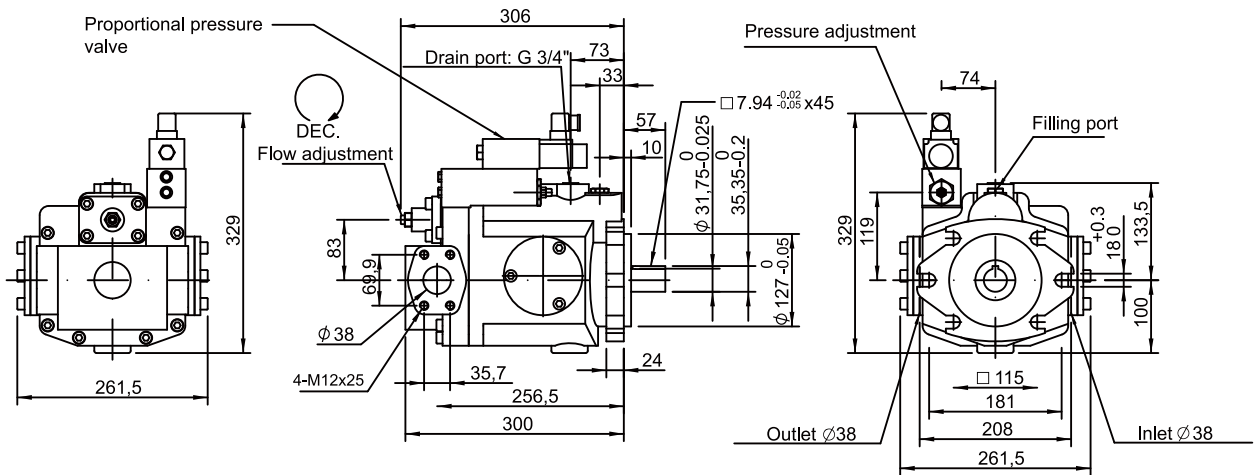

V50GR, V70GR Remote pressure compensator + Electrical unloading

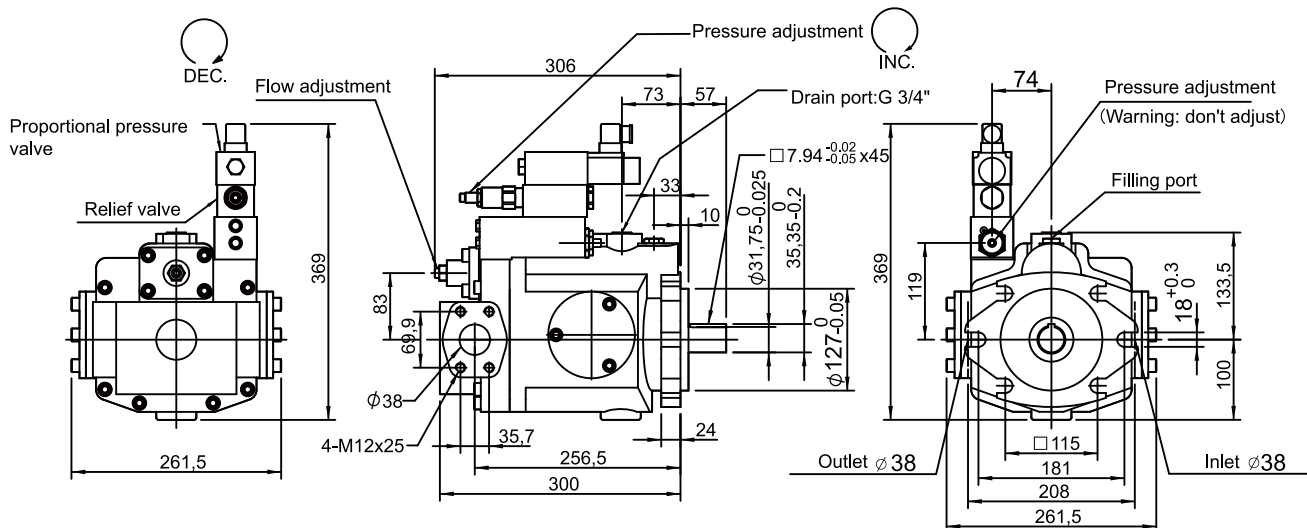

# Dimension

V50GB, V70GB Remote pressure compensator + 2-stage pressure control

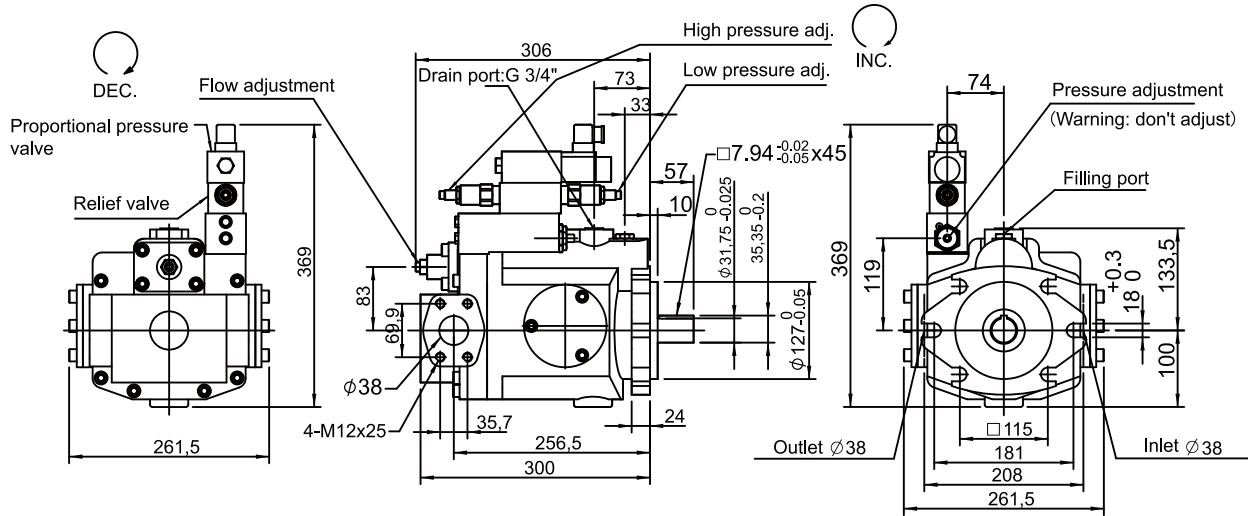

V50GC, V70GC Remote pressure compensator + Electrical unloading + 2-stage pressure control

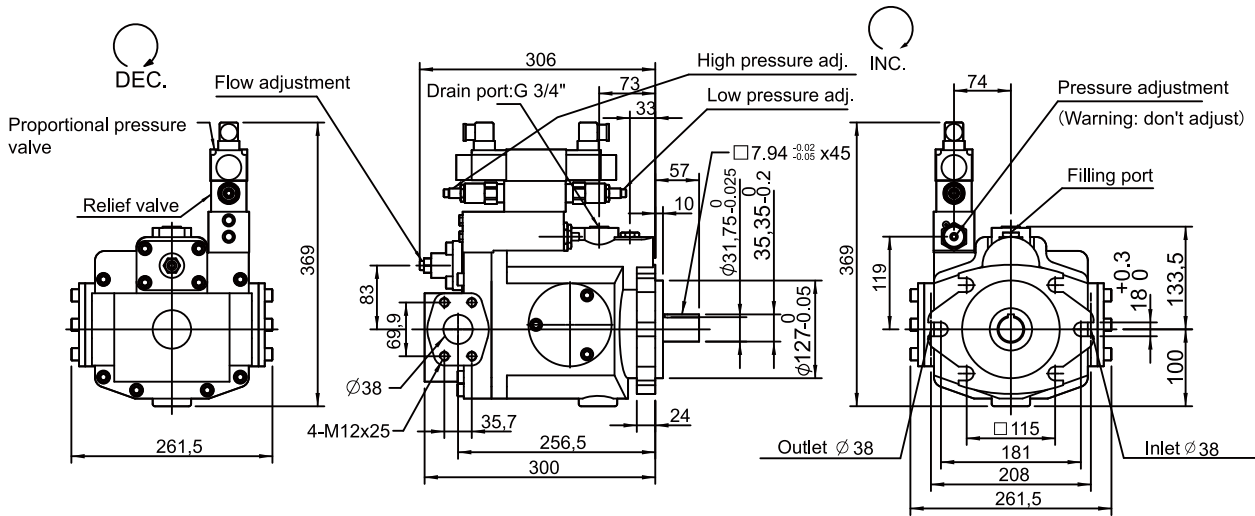

V50HQ, V70HQ Load-sensing compensator + Proportional flow valve + Relief valve

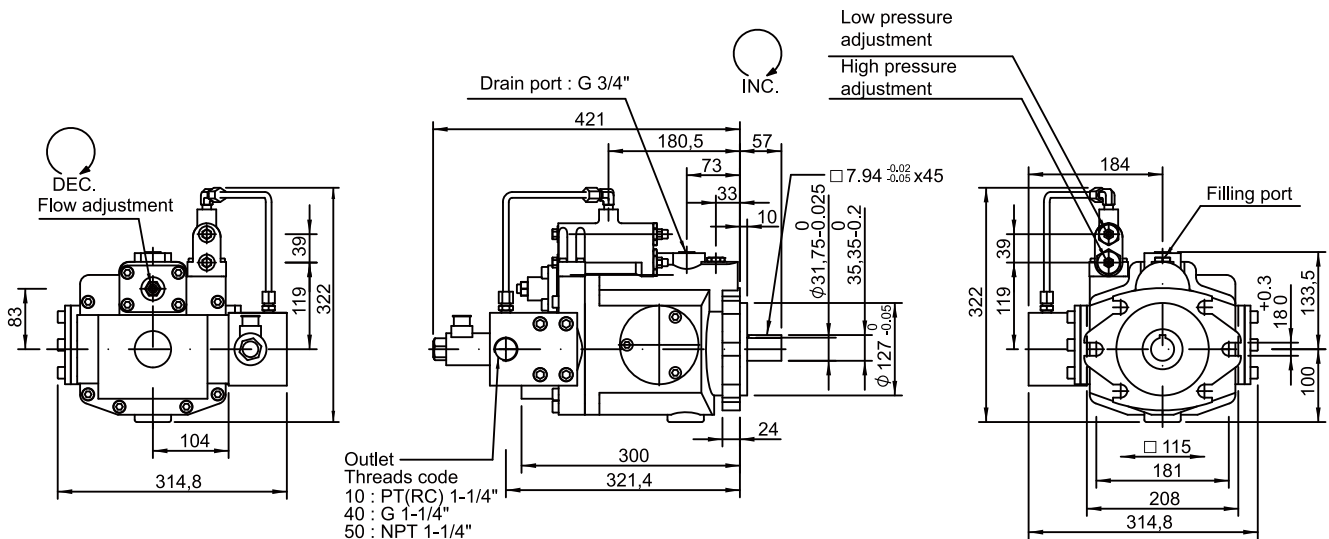



# Dimension

V50, V70 Rear port (Please following order code no.6 add "B")

V 50 □ □ □ □ B □ — □ □ □ □ □

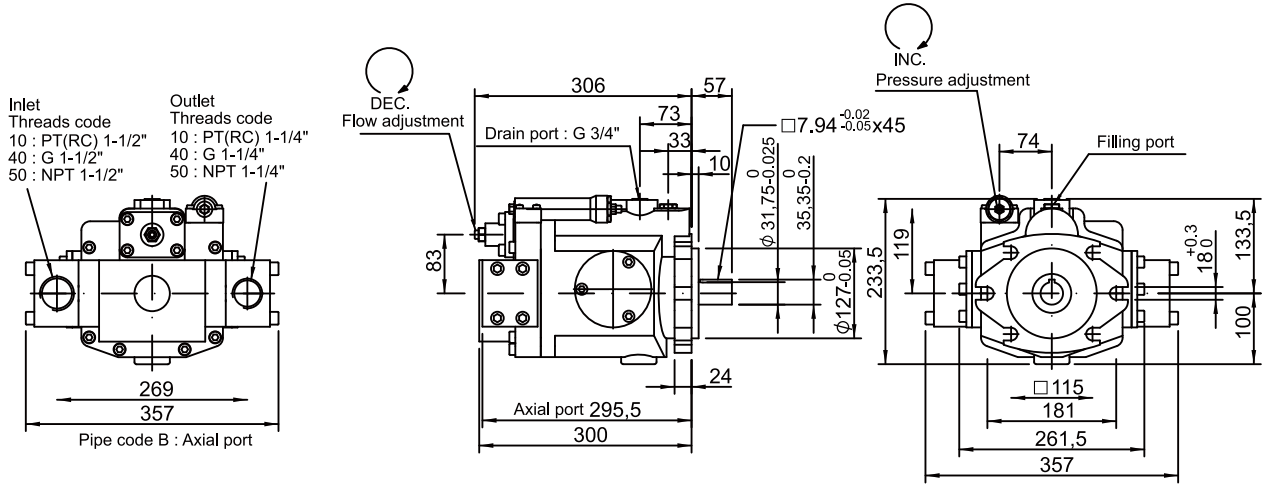

Type	A	B	C	CR	CG	D	DG	E	EG	F	FG	G	GJ	GM	HL	HK	HQ
○ Thru drive option	○	○	○	○	○	○	○	○	○	○	○	○	○	○	○		

V50, V70 Splined shaft type

V50, V70 Inlet / outlet

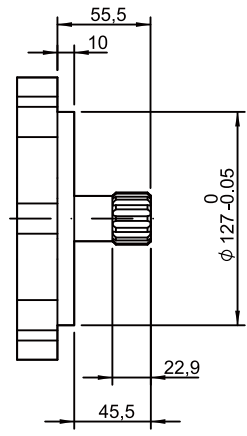

S: 14T DP12/24

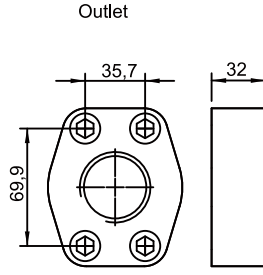

Threads code  
10 : PT(RC) 1-1/4"  
40 : G 1-1/4"  
50 : NPT 1-1/4"

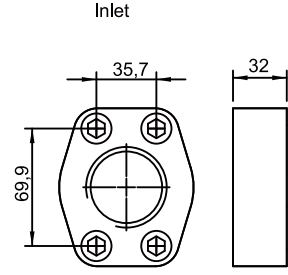

Threads code  
10 : PT(RC) 1-1/2"  
40 : G 1-1/2"  
50 : NPT 1-1/2"



# Pump combination

A

40

V Axial piston pump

Pump 1	V15 (V18)	V23 (V25)	V23 (V25)	V38 (V42)	V38 (V42)	V38 (V42)	V50 (V70)	V50 (V70)	V50 (V70)
Pump 2	V15 (V18)	V15 (V18)	V23 (V25)	V15 (V18)	V23 (V25)	V38 (V42)	V15 (V18)	V23 (V25)	V38 (V42)
A	G 3/8"	G 3/8"	G 3/8"	G 3/8"	G 3/8"	G 1/2"	G 3/8"	G 3/8"	G 1/2"
B	G 3/8"	G 3/8"	G 3/8"	G 1/2"	G 1/2"	G 1/2"	G 3/4"	G 3/4"	G 3/4"
C	57.45	57.45	61	57.45	61	73	57.45	61	73
D	35.1	35.1	52.4	35.1	52.4	58.7	35.1	52.4	58.7
E	35.1	35.1	26.2	35.1	26.2	30.2	35.1	26.2	30.2
F	35.1	52.4	52.4	58.7	58.7	58.7	69.9	69.9	69.9
G	35.1	26.2	26.2	30.2	30.2	30.2	35.7	35.7	35.7
H	M8x20	M8x20	M10x16	M8x20	M10x16	M10x16	M8x20	M10x16	M10x16
I	M8x20	M10x16	M10x16	M10x16	M10x16	M10x16	M12x25	M12x25	M12x25
J	147	147	170	147	170	179	147	170	179
K	147	170	170	179	179	179	256.5	256.5	256.5
L	332	369	402	378	401	410	464	493	502
M	382	419	455	428	454	465	515	546	555
N	48	48	51	48		51	48	51	51
O	48	51	51	51	51	51	73	73	73
P	6	9	9	9	9	9	10	10	10
Q	4.76x32	6.35x40	6.35x40	6.35x40	6.35x40	6.35x40	7.94x45	7.94x45	7.94x45
R	13	14	14	14.5	14.5	14.5	24	24	24
S	Ø19.05	Ø22.22	Ø22.22	Ø22.22	Ø22.22	Ø22.22	Ø31.75	Ø31.75	Ø31.75
T	21.15	25.08	25.08	25.08	25.08	25.08	35.35	35.35	35.35
U	Ø82.55	Ø101.6	Ø101.6	Ø101.6	Ø101.6	Ø101.6	Ø127	Ø127	Ø127
V	Ø25	Ø25	Ø25	Ø31	Ø31	Ø31	Ø38	Ø38	Ø38
W	Ø25	Ø25	Ø25	Ø31	Ø31	Ø31	Ø38	Ø38	Ø38
X	106	146	146	146	146	146	181	181	181
Y	131	146	146	160	160	160	208	208	208
Z	165	182	182	198.6	198.6	198.6	261.5	261.5	261.5
A1	44	39	39	39	39	39	74	74	74
A2	31.2	31.2	31.2	31.2	31.2	31.2	40	40	40
A3	5	5	5	5	5	5	8	8	8
A4	84	110	110	121	121	121	119	119	119
A5	11	13.5	13.5	13.5	13.5	13.5	18	18	18
A6	44.5	58.5	58.5	58.5	58.5	58.5	57	57	57
A7	160	193	193	210	210	210	233.5	233.5	233.5
A8	91.5	93	93	113.5	113.5	113.5	133.5	133.5	133.5
A9	60	68	68	72	72	72	100	100	100

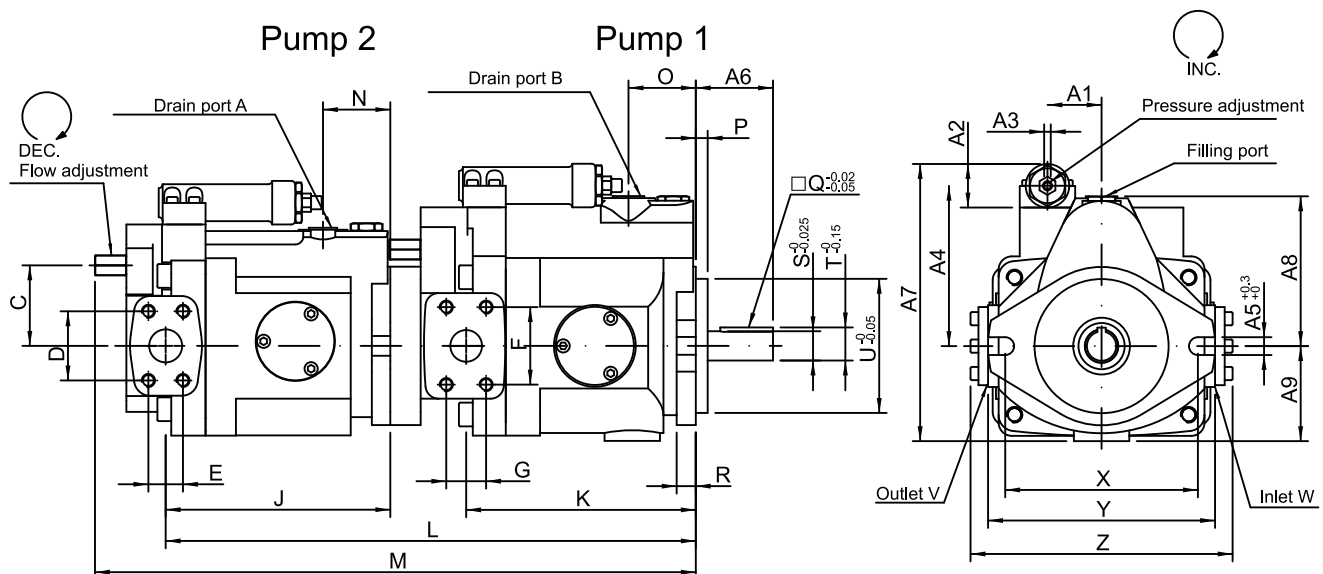

## Pump combination - coupling

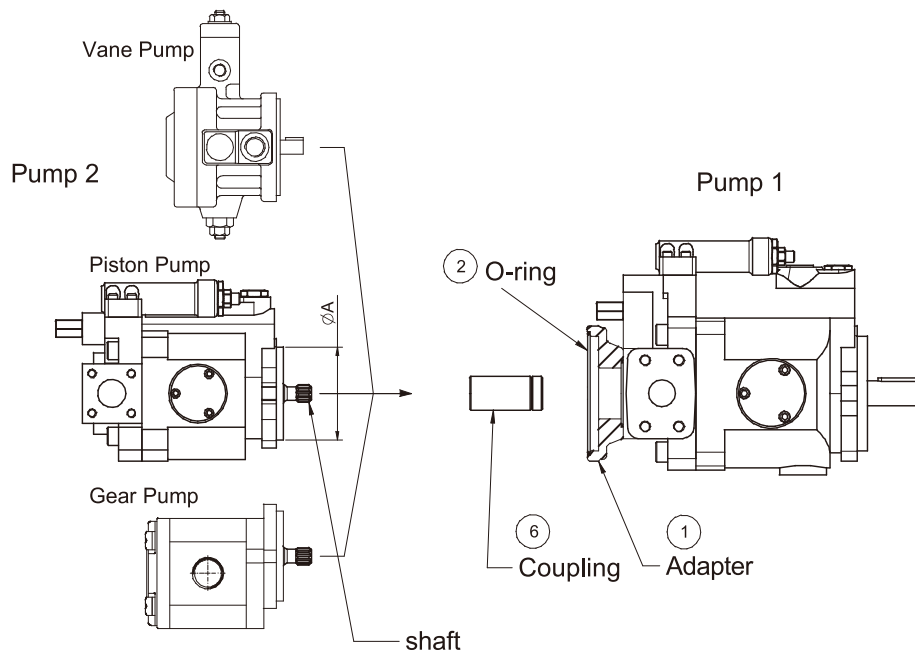

No	Pump 1	Pump 2			⑥Coupling	
	Model	Model	ØA	Shaft		
15-1	V15,V18	Piston pump: V15~18, AR16~22 Gear pump: HGP-3A	SAE Ø 82.55	9T 16/32 DP	COUP-V15+15	
23-1	V23, V25	Piston pump: V15~18, AR16~22 Gear pump: HGP-3A	SAE A Ø82.559T Vane pump Ø95.02	9T 16/32 DP	COUP-V23-1	
23-3A				13T 16/32 DP	COUP-V23-3	
23-5				Cylindric Ø19.05*4.76	COUP-V23-5	
23-6		Piston pump: V23~25 Vane pump: T6C	SAE B Ø101.6 Metric Ø100	Cylindric Ø22.22*6.35	COUP-V23-6	
23-3B		Cylindric Ø22.22*4.76				
38-1		13T 16/32 DP				
38-3A		Vane pump: T6C Gear pump: HGP-3A	SAE A Ø82.55 Vane pump Ø95.02	9T 16/32 DP	COUP-V38-1	
38-5		13T 16/32 DP		COUP-V38-3		
38-6		Cylindric Ø19.05*4.76		COUP-V38-5		
38-6		V38, V42	Piston pump: V23~25, V38~V42 Vane pump: T6C	SAE B Ø101.6 Metric Ø100	Cylindric Ø22.22*6.35	COUP-V38-6
38-7	Cylindric Ø22.22*4.76					
38-3B	Piston pump: PV016~023 Vane pump: PV2R2		SAE B Ø101.6 Metric Ø100	Cylindric Ø25.4*6.35	COUP-V38-7	
38-4				13T 16/32 DP	COUP-V38-3	
70-1				15T 16/32 DP	COUP-V38-4	
70-1	V50, V70	Piston pump: V15~18, AR16~22 Gear pump: HGP-3A Vane pump: F30,F40,PV2R1	SAE A Ø82.55 Vane pump Ø95.02	9T 16/32 DP	COUP-V70-1	
70-3A				13T 16/32 DP	COUP-V70-3	
70-5				Cylindric Ø19.05*4.76	COUP-V70-5	
70-6		Piston pump: V23~25, V38~V42 Vane pump: T6C	SAE B Ø101.6 Metric Ø100	Cylindric Ø22.22*6.35	COUP-V70-6	
70-7				Cylindric Ø22.22*4.76		
70-3B				Cylindric Ø25.4*6.35		COUP-V70-7
70-4				13T 16/32 DP		COUP-V70-3
70-4		15T 16/32 DP	COUP-V70-4			

Ø A	① Adapter	② O-ring
SAE A Ø82.55	23A-83-D	G80
Vane pump Ø95.02	23A-83-G	G95
SAE B Ø101.6	23A-83-E	G100
Metric Ø100	23A-83-J	G100

## Pump combination - coupling

A

42

V Axial piston pump

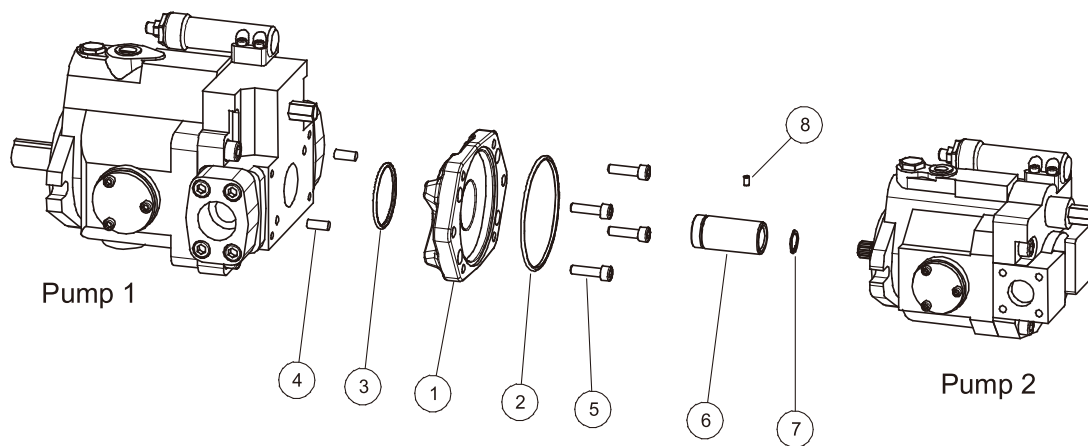

⑥ Coupling	⑦ Snap ring	Depending 2nd pump to use snap ring or not (● : With snap ring)			⑧ Screw
		Piston pump: V15~18, AR16	Gear pump: HGP- 3A	Vane pump: F30, F40	
COUP-V15+15	R13	●	●	●	--
COUP-V23-1	R13	●	●		--
COUP-V23-3	R20	●			--
COUP-V23-5	R20			●	M5 x8
COUP-V23-6	--				M5 x8
COUP-V38-1	R13	●	●		--
COUP-V38-3	R20	●			--
COUP-V38-4	--				--
COUP-V38-5	R20			●	M5 x8
COUP-V38-6	--				M5 x8
COUP-V38-7	--				M5 x8
COUP-V70-1	R13	●	●		--
COUP-V70-3	R20	●			--
COUP-V70-4	--				--
COUP-V70-5	R20			●	M5 x8
COUP-V70-6	--				M5 x8
COUP-V70-7	--				M5 x8

③ O-ring	G55
④ Pin	∅8x16 x2 nos
⑤ Screw	M8x30 x4 nos

## Pump combination - thru drive dimension

A

43

V Axial piston pump

V15,V18

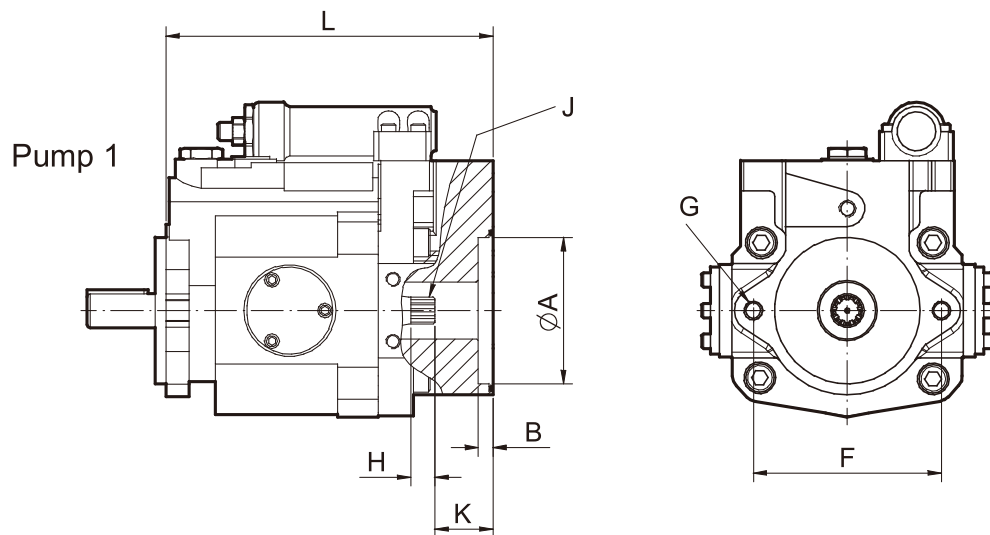

V23~V70

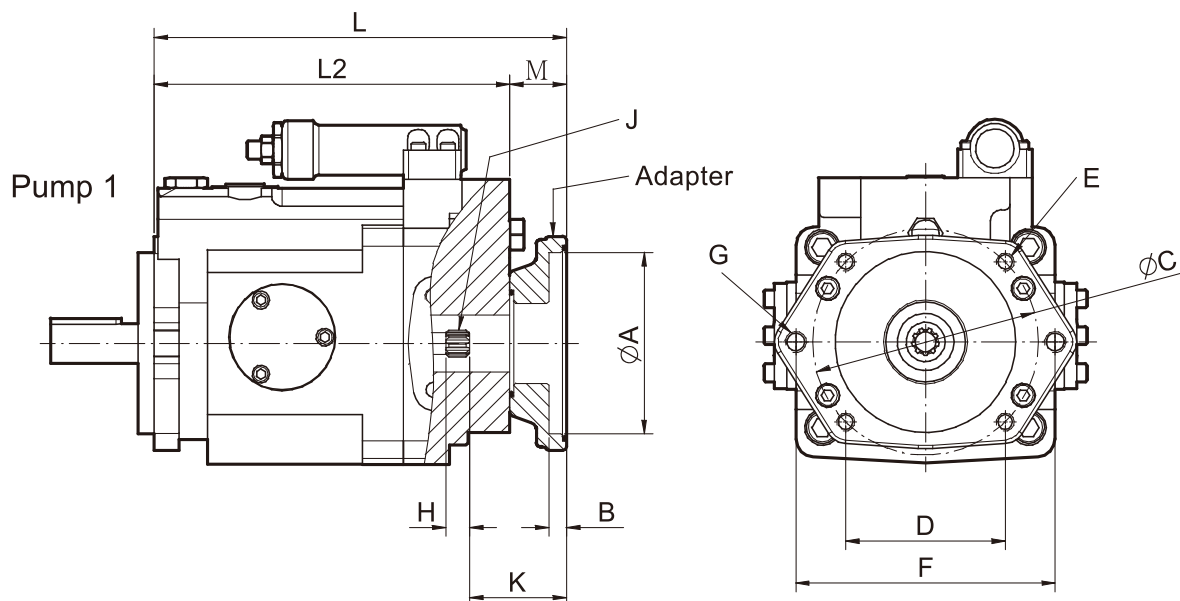

Model	2nd Pump	φA	B	φC	D	E	F	G
V15,V18	SAE A	φ82.55	8.35	--	--	--	106.3	M10xP1.5
	SAE A	φ82.55	8.35	φ127	89.8	M10xP1.5	106.3	M10xP1.5
V23~V70	SAE A	φ101.6	10	φ127	89.8	M10xP1.5	146	M12xP1.75
	Metric	φ100	10	φ125	88.39	M10xP1.5	140	M12xP1.75
	Vane Pump	φ95.02	8.35	--	90	M10xP1.5	--	--

Model	K	H	J	M	L	L2		
V15,V18	33	13.5	9T 16/32 DP	--	185	--		
V23,V25	59	13.5	9T 16/32 DP	32	237	205		
V38,V42	66	20	14T M1.25	32	241	209		
V50,V70	64.4	22	13T 16/32DP	32	332	300		

YEOSHE product specifications are subject to change with prior notice.



# Pump combination - thru drive dimension

A

44

V Axial piston pump

View A

Pump 1 V15, Pump 2 V15

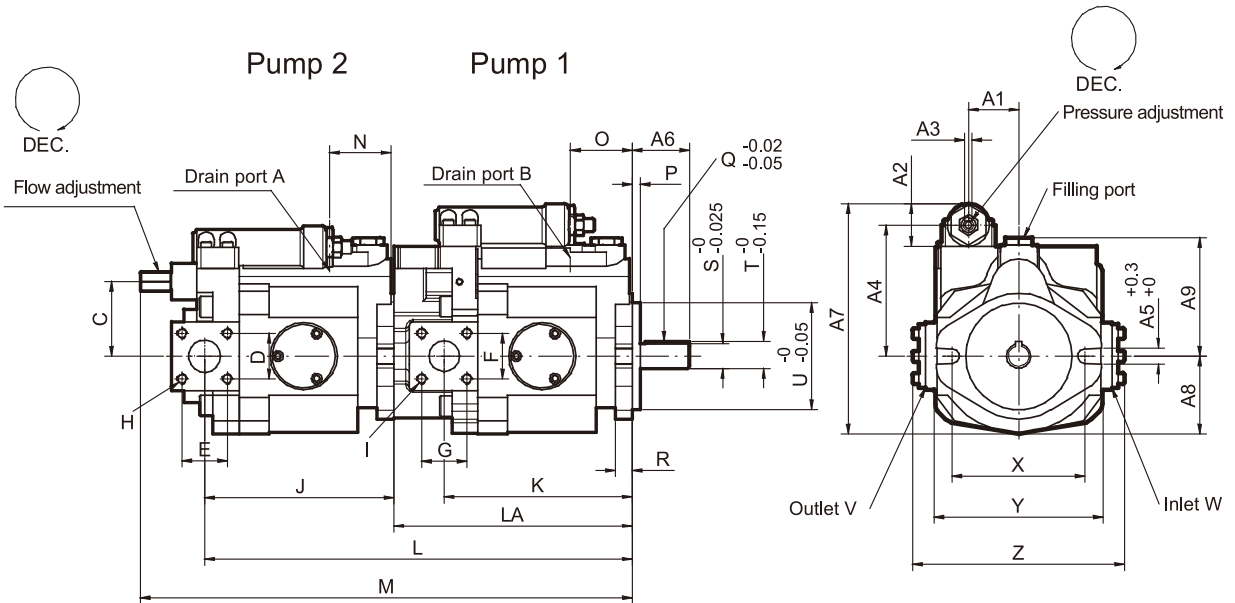

View B

Pump 1 V23~V70, Pump 2 V15~V38

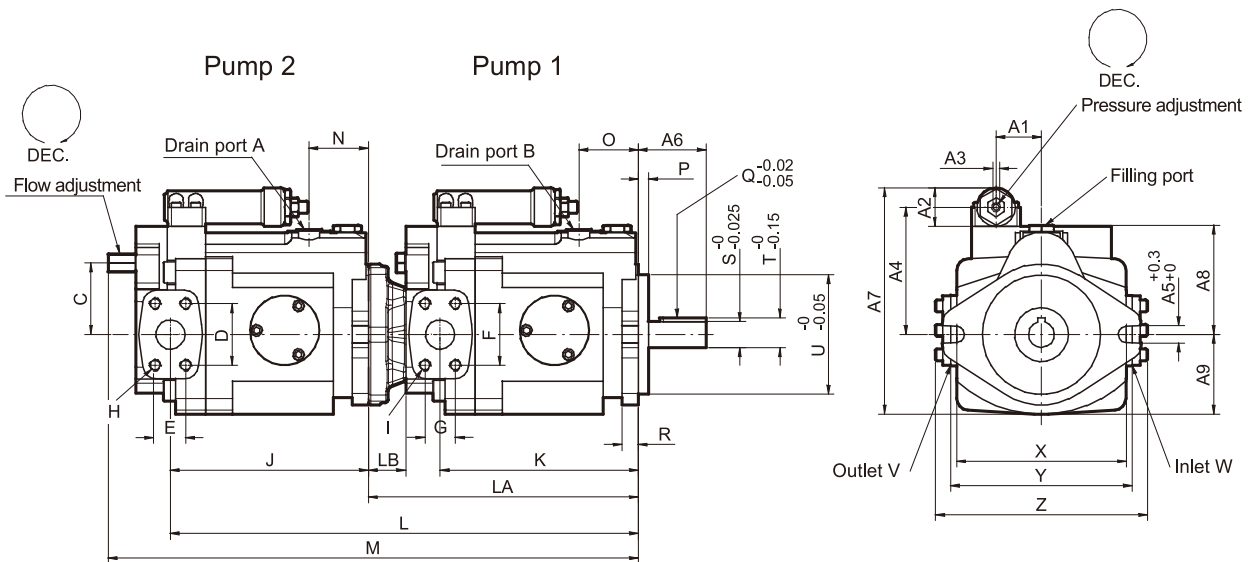

## Pump combination - thru drive dimension

A

45

V Axial piston pump

Pump 1	Pump 2	A	B	C	D	E	F	G	H	I
V15,V18	V15,V18	G 3/8" (RC 3/8")	G 3/8" (RC 3/8")	57.45	35.1	35.1	35.1	35.1	M8xP1.25x20	M8xP1.25x20
V23,V25	V15,V18	G 3/8" (RC 3/8")	G 3/8" (RC 3/8")	57.45	35.1	35.1	52.4	26.2	M8xP1.25x20	M10xP1.5x16
V23,V25	V23,V25	G 3/8" (RC 3/8")	G 3/8" (RC 3/8")	61	52.4	26.2	52.4	26.2	M10xP1.5x16	M10xP1.5x16
V38,V42	V15,V18	G 3/8" (RC 3/8")	G 1/2" (RC 1/2")	57.45	35.1	35.1	58.7	30.2	M8xP1.25x20	M10xP1.5x16
V38,V42	V23,V25	G 3/8" (RC 3/8")	G 1/2" (RC 1/2")	61	52.4	26.2	58.7	30.2	M10xP1.5x16	M10xP1.5x16
V38,V42	V38,V42	G 1/2" (RC 1/2")	G 1/2" (RC 1/2")	73	58.7	30.2	58.7	30.2	M10xP1.5x16	M10xP1.5x16
V50,V70	V15,V18	G 3/8" (RC 3/8")	G 3/4" (RC 3/4")	57.45	35.1	35.1	69.9	35.7	M8xP1.25x20	M12xP1.75x25
V50,V70	V23,V25	G 3/8" (RC 3/8")	G 3/4" (RC 3/4")	61	52.4	26.2	69.9	35.7	M10xP1.5x16	M12xP1.75x25
V50,V70	V38,V42	G 1/2" (RC 1/2")	G 3/4" (RC 3/4")	73	58.7	30.2	69.9	35.7	M10xP1.5x16	M12xP1.75x25

Pump 1	Pump 2	J	K	L	LA	LB	M	N	O	P	Q	R	S	T	U
V15,V18	V15,V18	147	147	332	185	--	382	48	48	6	4.76x32	13	∅19.05	21.15	∅82.55
V23,V25	V15,V18	147	170	384	237	32	411	48	51	9	6.35x40	14	∅22.22	25.08	∅101.6
V23,V25	V23,V25	170	170	407	237	32	455	51	51	9	6.35x40	14	∅22.22	25.08	∅101.6
V38,V42	V15,V18	147	179	388	241	32	438	48	51	9	6.35x40	14.5	∅22.22	25.08	∅101.6
V38,V42	V23,V25	170	179	411	241	32	464	51	51	9	6.35x40	14.5	∅22.22	25.08	∅101.6
V38,V42	V38,V42	179	179	420	241	32	473	51	51	9	6.35x40	14.5	∅22.22	25.08	∅101.6
V50,V70	V15,V18	147	256.5	479	332	32	529	48	73	10	7.94x45	24	∅31.75	35.35	∅127
V50,V70	V23,V25	170	256.5	502	332	32	555	51	73	10	7.94x45	24	∅31.75	35.35	∅127
V50,V70	V38,V42	179	256.5	511	332	32	564	51	73	10	7.94x45	24	∅31.75	35.35	∅127

Pump 1	Pump 2	V	W	X	Y	Z	A1	A2	A3	A4	A5	A6	A7	A8	A9
V15,V18	V15,V18	∅25	∅25	106	131	165	44	31.2	5	84	11	44.5	160	91.5	60
V23,V25	V15,V18	∅25	∅25	146	146	182	39	31.2	5	110	13.5	58.5	193	93	68
V23,V25	V23,V25	∅25	∅25	146	146	182	39	31.2	5	110	13.5	58.5	193	93	68
V38,V42	V15,V18	∅31	∅31	146	160	198.6	39	31.2	5	121	13.5	58.5	210	113.5	72
V38,V42	V23,V25	∅31	∅31	146	160	198.6	39	31.2	5	121	13.5	58.5	210	113.5	72
V38,V42	V38,V42	∅31	∅31	146	160	198.6	39	31.2	5	121	13.5	58.5	210	113.5	72
V50,V70	V15,V18	∅38	∅38	181	208	261.5	74	40	8	119	18	57	233.5	133.5	100
V50,V70	V23,V25	∅38	∅38	181	208	261.5	74	40	8	119	18	57	233.5	133.5	100
V50,V70	V38,V42	∅38	∅38	181	208	261.5	74	40	8	119	18	57	233.5	133.5	100



**YEOSHE HYDRAULICS CO., LTD.**  
**YEOSHE BEST CHOICE**

*Innovative Technology*  
*Efficient Performance*  
*Reliable Quality and Service*

油聖液壓科技有限公司  
YEOSHE HYDRAULICS TECHNOLOGY CO.,LTD.

413 台灣台中市霧峰區霧工一路68號  
No.68, Wugong 1st Rd., Wufong Dist., Taichung City, Taiwan, 413  
TEL : +886-4-23332339 FAX : +886-4-23333817 E-mail : yeoshe@yeoshe.com.tw

東莞辦事處 Dongguan TEL : +86-769-85965158 FAX : +86-769-81635359 E-mail : yeoshe@yeoshe.com.tw  
上海辦事處 Shanghai TEL : +86-21-69785786 FAX : +86-21-69785787 E-mail : yeoshe@yeoshe.com.tw

經銷商 Distributor

[www.yeoshehydraulic.com](http://www.yeoshehydraulic.com)

版權所有 翻印必究  
Copyright © 2019 by YEOSHE